



**NEW FLYER**

---

# **RMWB - FORT MCMURRAY**

## **OPERATOR'S GUIDE**

### **DIESEL 40FT. LOW FLOOR TRANSIT BUS**

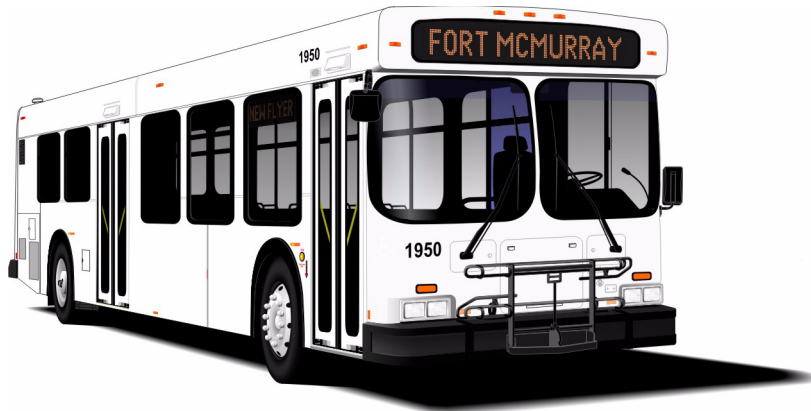

This operator's guide is effective for only those coaches with the following Identification Numbers:

### **SR1302**

<b>Vehicle Identification Number</b>	<b>Unit Number</b>
2FYD4FV168E034986	1950
2FYD4FV188E034987	1951
2FYD4FV1X8E034988	1952
2FYD4FV118E034989	1953
2FYD4FV188E034990	1954



**NEW FLYER**

---



**COPYRIGHT © 2009 NEW FLYER INDUSTRIES CANADA ULC.  
ALL RIGHTS RESERVED.**

No part of this manual and/or data herein may be reproduced or transmitted in any form or by any means, electronic or mechanical, including photocopying, recording, or information recording and retrieval systems, for any purpose, without the express written permission of New Flyer Industries Canada ULC.

“New Flyer” is a tradename of “New Flyer Industries Canada ULC”

The information contained in this manual is updated periodically. While great care is taken in compiling the information contained in this manual, New Flyer Industries Canada ULC cannot assume liability for losses of any nature arising from any errors and/or omissions.

The information and specifications contained throughout this manual are up to date at the time of publication. New Flyer Industries Canada ULC reserves the right to change the content of this manual at anytime without notice.

Printed in Canada



**NEW FLYER**

---



## Table of Contents

<b>INTRODUCTION</b> .....	<b>1</b>
Vehicle Specifications .....	2
Vehicle Identification .....	6
Warnings & Cautions .....	6
Contacting New Flyer.....	6
<b>SAFETY INFORMATION</b> .....	<b>7</b>
Safety Procedures.....	7
Safety Equipment.....	7
Escape Exits .....	8
Exit Door Sensitive Edges.....	11
Interlock System.....	11
<b>TO ENTER THE VEHICLE</b> .....	<b>12</b>
<b>DRIVER'S CHECK LIST</b> .....	<b>13</b>
Exterior.....	13
Interior.....	17
<b>DRIVER'S AREA</b> .....	<b>21</b>
Driver's Window .....	21
Mirrors.....	23
Roller Blinds.....	24
Driver's Locker .....	24
Driver's Seat.....	25
Steering Wheel & Horn .....	27
Public Address System .....	29
Destination/Route Signs.....	30
<b>INSTRUMENTATION &amp; CONTROLS</b> .....	<b>33</b>
Instrument Panel .....	33
Driver's Climate Controls .....	44
Side Console Switch Panel.....	46
Foot Operated Controls.....	57
Miscellaneous Controls .....	58
<b>VEHICLE OPERATION</b> .....	<b>61</b>
Pre-Start Checks & Adjustments.....	61
Transmission Operation .....	61
Retarder Operation .....	63
Anti-Lock Braking System .....	64
Starting the Engine.....	65
Operational Checks.....	67
Day-Time Operation.....	69
Night-Time Operation.....	70
Pre-Trip Brake Test.....	70



Moving the Vehicle.....	72
Parking the Vehicle.....	73
Jump Start Connection.....	74
Engine Protection System.....	74
Kneeling.....	74
Passenger Signal System.....	75
<b>WHEELCHAIR SYSTEM.....</b>	<b>77</b>
Wheelchair Ramp.....	77
Wheelchair Restraint System.....	81
<b>BIKE RACK SYSTEM.....</b>	<b>83</b>
Loading Operation.....	83
Unloading Operation.....	83
<b>NOTES.....</b>	<b>84</b>



# 1. INTRODUCTION

This manual describes the operating features and safety equipment of the New Flyer transit vehicle. All personnel involved in the operation of the vehicle should be acquainted with this manual and should familiarize themselves with the vehicle, before providing any public service. Knowing the contents of this booklet and following its recommendations will help to assure safe and trouble-free operation.

It is not the intention or responsibility of this manual to give instruction in the use of common sense, basic skills and rules of driving; therefore, it is assumed that you, the operator, are fully qualified to operate a public transit vehicle.

This manual and any other supplied should be considered a permanent part of the vehicle and remain with the vehicle at all times. The information and specifications throughout this manual are up to date at time of publication. New Flyer reserves the right to change the content of this manual at any time without notice. Any malfunction which interferes with the safe operation of the vehicle should be reported immediately to the appropriate service personnel.

**NOTE:**

*New Flyer urges you the driver to read this publication carefully, as well as the following manuals which are readily available from the respective manufacturer.*

- *Allison Transmission B400R Operator's Manual*
- *Cummins ISL Series Engine Owner's Manual*

**VEHICLE SPECIFICATIONS**

<b>VEHICLE TYPE</b>	
Model	<i>New Flyer</i> D40LF transit bus
Customer	RMWB - Fort McMurray - SR1302
Build Year	2009
<b>ENGINE &amp; FUEL</b>	
Engine	<i>Cummins</i> ISL07
Horsepower	280 HP - 900 ft-lb.
Fuel	Ultra low sulphur diesel
Usable Fuel Capacity	125 U.S. gallons (473 liters)
<b>TRANSMISSION</b>	
Transmission	<i>Allison</i> B400R with 4th Generation controls
Self-Contained Retarder	25% accelerator, 75% brake activated
<b>DIMENSIONS</b>	
Length (over bumpers)	40.8 ft. (12.4 m)
Width	8.5 ft. (2.6 m)
Height	10.1 ft. (3.1 m)
Wheelbase	24.4 ft. (7.4 m)
Turning Radius	44 ft. (13.4 m)
Vehicle Weight (approx.)	26,880 lbs. (12,195 kg)
Gross Vehicle Weight Rating (GVWR)	42,540 lbs. (19,290 kg)
<b>AXLES &amp; SUSPENSION</b>	
Front Axle	<i>MAN</i> V8 65L
Front Gross Axle Weight Rating (GAWR)	14,780 lbs. (6,700 kg)
Rear Axle	<i>MAN</i> HP - 1352 - B (5.44:1)
Rear Gross Axle Weight Rating (GAWR)	27,760 lbs. (12,590 kg)
Suspension	Air springs & shock absorbers



**WHEELS & TIRES**

Tires	<i>Goodyear 305/70R22.5</i>
Rim Mounting	10 bolt hub piloted
Maximum Load	Single Tires - 7,390 lbs. @ 115 psi Dual Tires - 6,940 lbs. @ 115 psi

**DESTINATION & ROUTE SIGNS**

Front Destination	<i>Luminator electronic</i>
Side Destination	<i>Luminator electronic</i>
Rear Route	<i>Luminator electronic</i>

**LIGHTING**

Interior	<i>Hadley/Transmatic L20 24 volt fluorescent lights</i>
----------	---

**HEATING & VENTILATION SYSTEM**

Heating Unit	<i>Thermo King TH-11 rear mount unit</i>
Auxiliary Heaters	<i>1 Mobile Climate Control heater/defroster unit</i>
	<i>2 Mobile Climate Control heaters</i>
	<i>1 Mobile Climate Control step heater</i>
	<i>2 Warm Wall convectors &amp; blower assemblies</i>
	<i>Entrance &amp; exit door deflected heat</i>
Auxiliary Coolant Heater	<i>Webasto Thermo 300</i>

**SEATING**

Driver's	<i>USSC 9100ALX</i>
Passenger	<i>American/Otaco Seating Metropolitan</i>
Seating Capacity	38
Wheelchair Stations	2 (seats fold up & lock)

**BRAKE SYSTEM**

Mechanical Components	Internal expanded S-cam type
	Automatic slack adjusters
Service Brake	Full air operated
	<i>Meritor Wabco</i> ABS controlled
Parking Brake	Spring applied, air released
Emergency Brake	Spring brake applied
	Brake treadle modulated to control

**WINDOWS**

General	<i>StormTite</i> black anodized frame (top tip-in, bottom fixed)
	44% grey laminated glass
Emergency Escape	2 curbside & 2 streetside windows
Driver's Window	2 piece full sliding interior & exterior handle
	72% green tinted glass

**DOORS**

Entrance	<i>Vapor</i> medium slide glide
Exit	<i>Vapor</i> wide slide glide
Controls	5-position door controller located on side console Exit door driver enabled, passenger operated
	Entrance door manual dump valve, located on vertical face of driver's side console

**ACCESSIBILITY FEATURES**

Wheelchair Ramp	<i>New Flyer</i> hydraulically-operated, located at entrance door
Kneeling	Full front suspension

**SAFETY FEATURES**

Emergency Escape Exits	2 curbside & 2 streetside windows
	2 roof hatches
Fire Extinguisher	5 lb. ABC rating, located behind the driver's seat
Emergency Air Release Control Valve	Entrance & exit doors
Accelerator & Brake Interlocks	Activated when entrance or exit door are opened or enabled, vehicle kneels or wheelchair ramp operates, parking brake is applied, hill holder switch is on, or exit door emergency valve is activated.
Sensitive Edges	Exit door
Drunk Alarm	
Silent Alarm	Located on edge of the side console

**MULTIPLEXING SYSTEM**

Vansco Multiplex System VMM J1939 Network	VMM 2820 VMM 1210 Pocket Gateway
---	--

## Vehicle Identification

The New Flyer vehicle identification plate is located in the driver's area of the vehicle interior. The plate lists the Gross Vehicle Weight Ratings (GVWR), the Vehicle Identification Number (VIN) and the Gross Axle Weight Ratings (GAWR) for all axles.

## Warnings & Cautions

Two types of headings are used in this guide to attract your attention. These notations will be highlighted with the icons below.



**Used when an operating procedure or practice, if not correctly followed, could result in personal injury or loss of life.**



**Used when an operating procedure or practice, if not strictly observed, could result in damage to or destruction of equipment.**

## Contacting New Flyer

If additional information is required, contact the Customer Service Department of:

New Flyer Industries Canada ULC  
25 DeBaets Street  
Winnipeg, Manitoba  
Canada  
R2J 4G5  
tel: (204) 934-4874  
fax: (204) 224-0248



## 2. SAFETY INFORMATION

### Safety Procedures

Do not drive the vehicle if:

- Indicators, instruments or gauges show that a major vehicle operating system is malfunctioning.
- Exhaust fumes seep into the passenger compartment.
- Beneath the vehicle, puddles of engine oil, hydraulic fluid, or coolant have formed.
- Seating stanchions and grab rails are loose or damaged.
- Driving mirrors are broken, missing or cannot be properly adjusted.
- Any exterior or interior light is broken, discolored, or malfunctioning.

Report the occurrence of any of the above to maintenance personnel so the vehicle can be serviced before beginning revenue service.

- Do not operate the vehicle without fastening the seat-belt.
- Make sure obstructions do not block or interfere with your safe range of driving and operating vision.
- Have any debris or garbage removed from the passenger area and the doors. This is important to eliminate any foot obstructions that could cause tripping or falling.
- Make sure all exterior and interior access doors and panels are securely shut and latched.
- Do not smoke around the fuel storage areas, the fuel filling area or during refueling. Do not smoke in areas where fuel, hydraulic fluid, transmission oil or any other flammable fluid has leaked.

### Safety Equipment

A hand-held fire extinguisher is located behind the driver's seat. Use the extinguisher only after the vehicle is in a safe location, and all passengers are evacuated. Use only if there is no risk to your personal safety.



## Escape Exits

### Side Windows

Two curbside and two streetside windows function as emergency exits and are identified by decals on the window panels.

To operate the emergency window, pull the red handle down and hold. Push out on the bottom of the window frame. The window will open on hinges at the top of the frame. To close, release the handle and slam window shut.

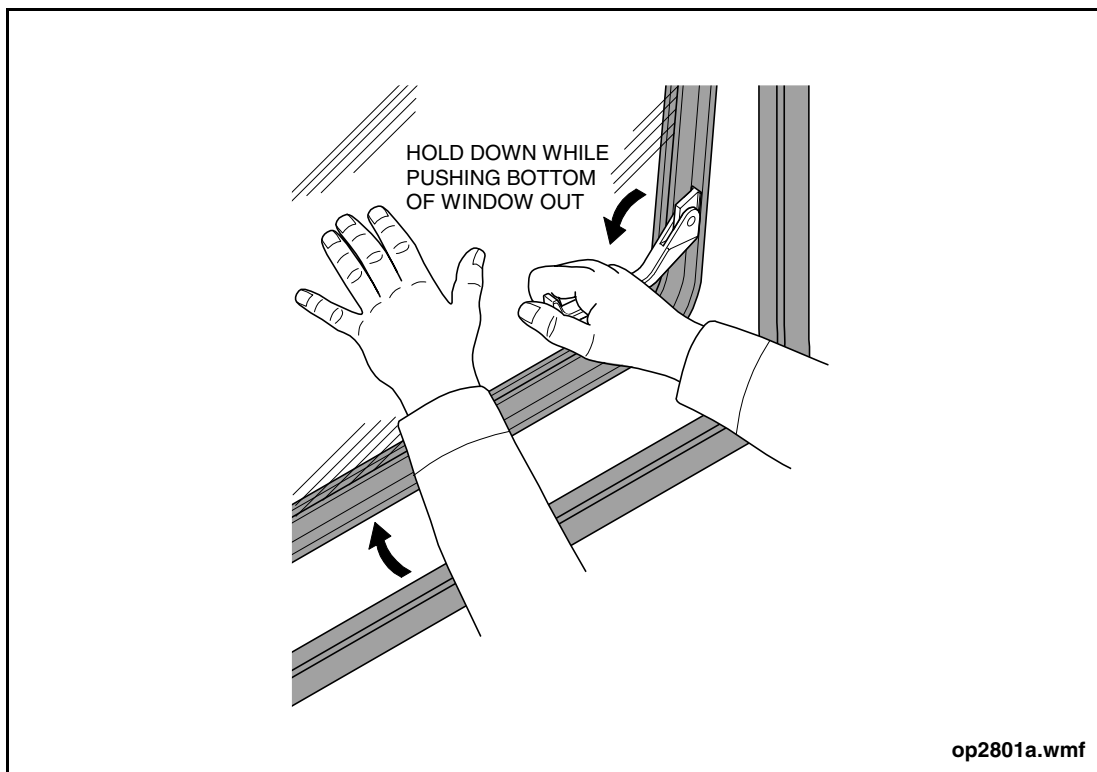

**Figure 1: Window Emergency Handle**



## Roof Hatches

Both roof hatches are usable for ventilation and/or as emergency exits.

### For Ventilation

Open the hatch to the desired position by holding the handles and exerting outward pressure toward the end being opened. To close the vent, grasp the handles and pull the hatch downward.

The most effective hatch positions for ventilation are:

- Front hatch - forward end open.
- Rear hatch - rear end open or fully open.

This allows fresh air to enter the front vehicle hatches while warmed, stale air escapes through the rear vehicle hatch.

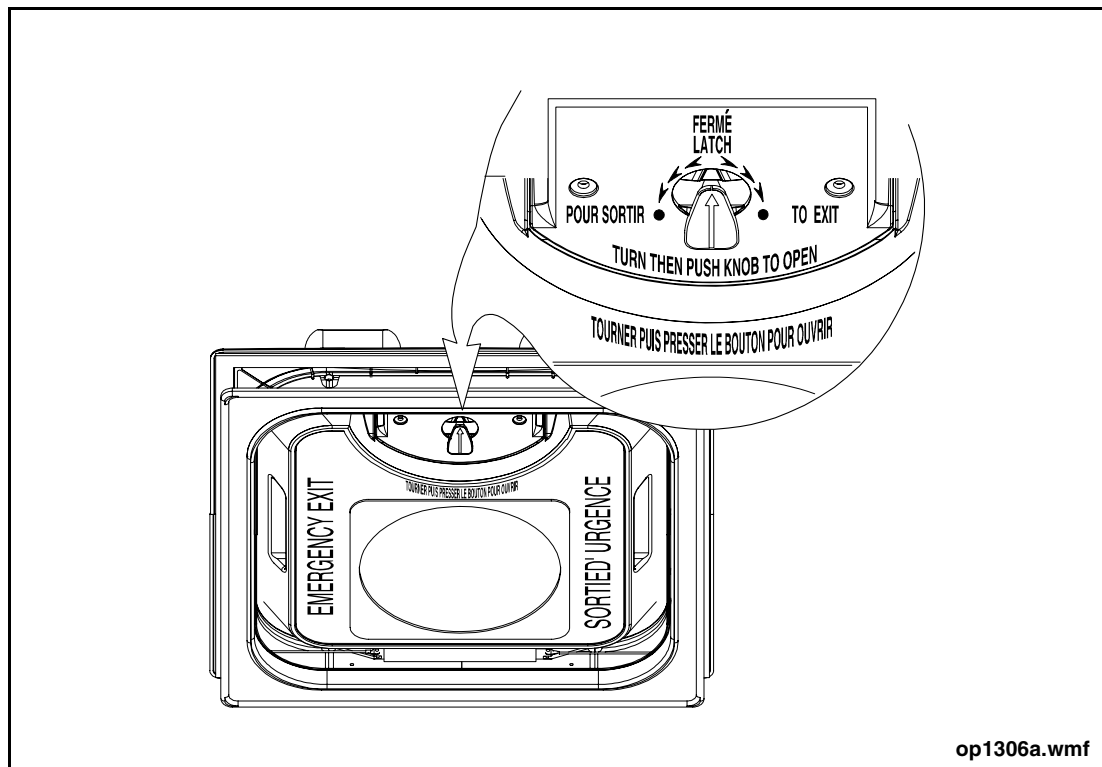

**Figure 2: Roof Hatch**



**For Emergency Exit**

1. Push the hatch up to the full OPEN venting position.
2. Turn the release latch knob 90° left or right to unlock.
3. Push the handle outward so the hatch swings open on the fixed hinge.
4. To close, return the hatch to its full OPEN position. Line up and push the separated hinge halves together. Turn the latch knob to the latched position.
5. Push up on the hatch to ensure proper engagement. Pull the hatch downwards to close.

**Entrance Door, Emergency Release Control Valve**

The door emergency exit control valve is located behind a breakable window in the door mechanism access cover. In an emergency, break the window to access the control valve knob. Rotate the knob 90° and push the doors open. As the doors open they activate the header, and curb lights.

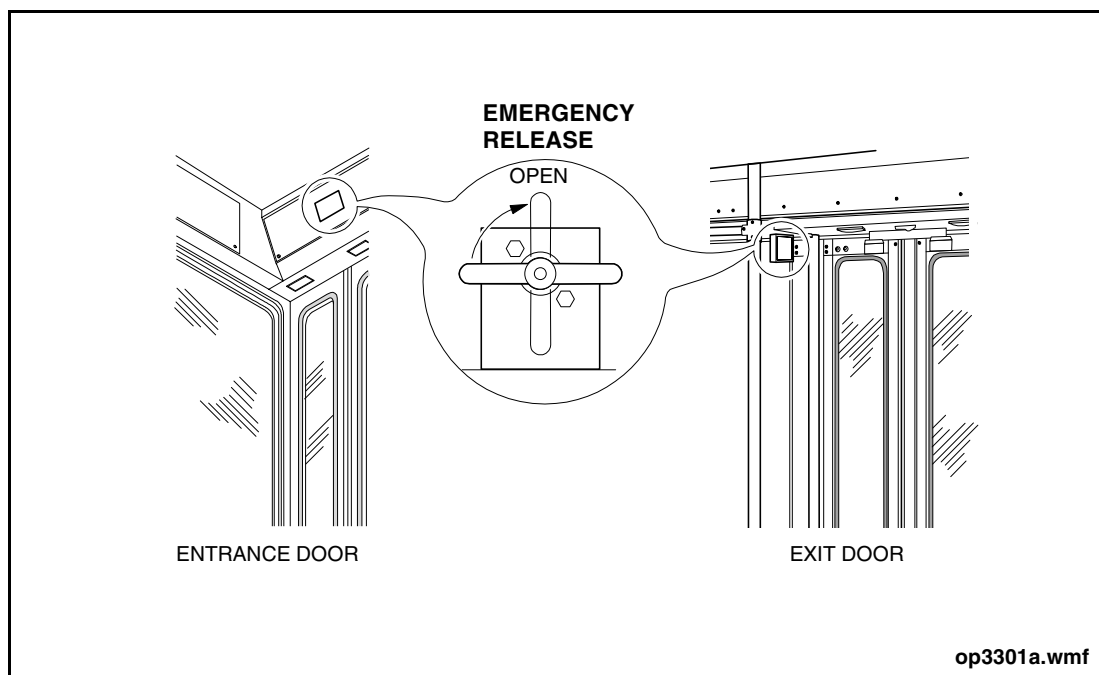

**Figure 3: Passenger Door Emergency Release**





## Exit Door, Emergency Release Control Valve

The door emergency exit control valve is located to the left of the exit door header, behind a breakable window. In an emergency, break the window to access the control valve knob. Rotate the control valve knob 90° and push the doors open. As the doors open they activate the header, and curb lights, the interlocks and the Rear Door Open indicator.

## Exit Door Sensitive Edges

Pressure sensitive rubber seals are mounted to the leading edges of the exit door panels. If they encounter an object or passenger during door closure, an alarm sounds and the doors fully reopen. The doors will again close once they have fully reopened.



### **NOTE:**

*The Interlock System prevents the vehicle from moving until the exit doors have fully closed.*

## Interlock System

Interlocks disable the accelerator and apply the rear brakes. The interlocks function only when the Master Run switch is in DAY-RUN or NIGHT-RUN position, the Door Master switch is in the ON position, the vehicle speed is below 2 mph, and any of the following conditions occur:

- Entrance or exit doors are opened or enabled.
- Exit door emergency valve is actuated.
- Vehicle is kneeling.
- Wheelchair ramp is not stowed.
- Hill Start switch is in the ON position.
- Parking brake is applied.

The Interlock System is intended to protect passengers from inadvertent vehicle movement. The Door Master switch can be used to disable the system for maintenance purposes or in an emergency. Refer to “Door Master Switch” in this manual for further information on switch operation.



### **NOTE:**

*The brake treadle must be momentarily depressed to release the interlocks.*



### 3. TO ENTER THE VEHICLE

1. Slide the front portion of the driver's window back to gain access to the door controller handle on the side console.
2. Turn the door controller handle to position #2, #3 or #5 to open the entrance door.
3. If the entrance door does not open, exhaust air by turning the door manual control valve on the side console to the OFF position. Open the door manually by pulling out the door halves at the seal.

**NOTE:**

*Take care not to damage the door seal when pulling the door open.*

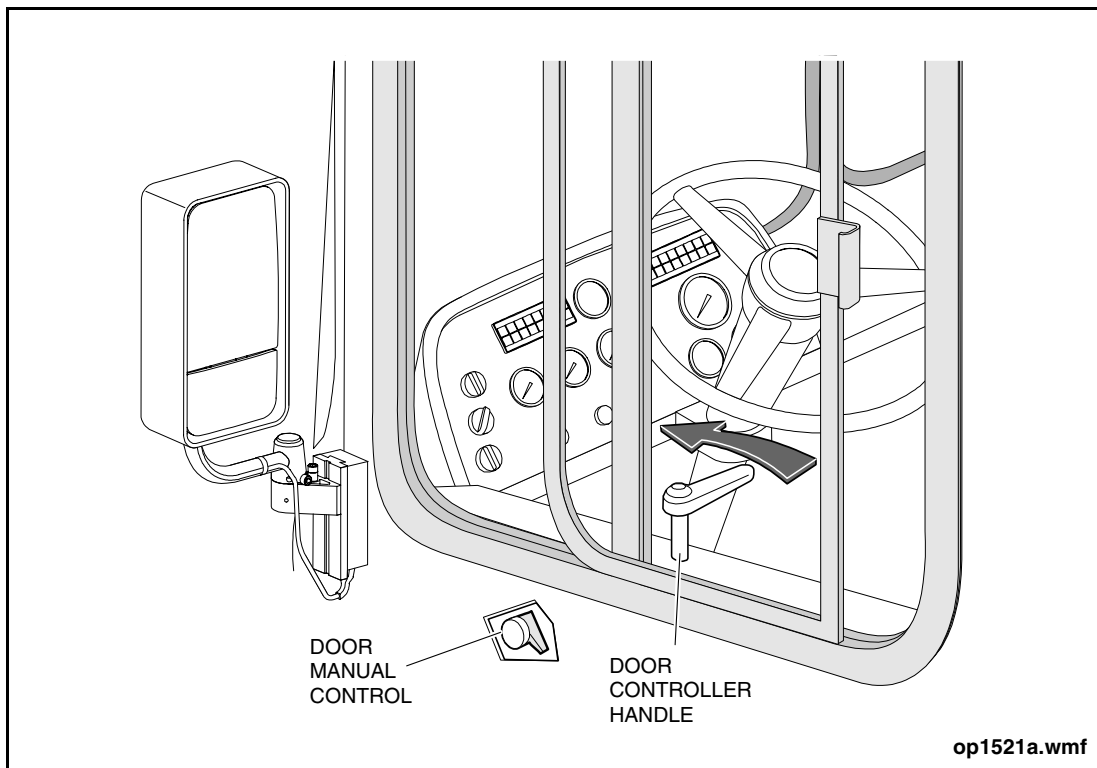

**Figure 4: To Enter the Vehicle**



## 4. DRIVER'S CHECK LIST

Check the following before putting the vehicle into transit service. Any problems discovered should be brought to the attention of the service personnel.

### Exterior

#### General

- Battery Disconnect switch is in the ON position.
- Engine Run switch in engine compartment is in the FRONT position.
- Check for any fluid puddles under the vehicle.
- Check all exterior panels for any visible damage.
- Check the air intake grille and the exhaust tailpipe for any blockage.
- Bumpers are securely mounted and no damage is evident.
- Bike rack is securely mounted and functions properly.

#### Access Doors

- Visually inspect door panels for any evidence of damage.
- Check that the access doors unlatch and open easily. Ensure gas struts function properly and maintain door in opened position (where applicable).
- Inspect door panel interior rubber bumpers condition or whether missing.
- All access doors must be closed and securely latched (where applicable) prior to operating vehicle.

#### Windows

- Check that all windows are closed.
- Ensure window glass is clean and no visible evidence of cracks or other damage.
- Inspect condition of window frames and seals for any damage.

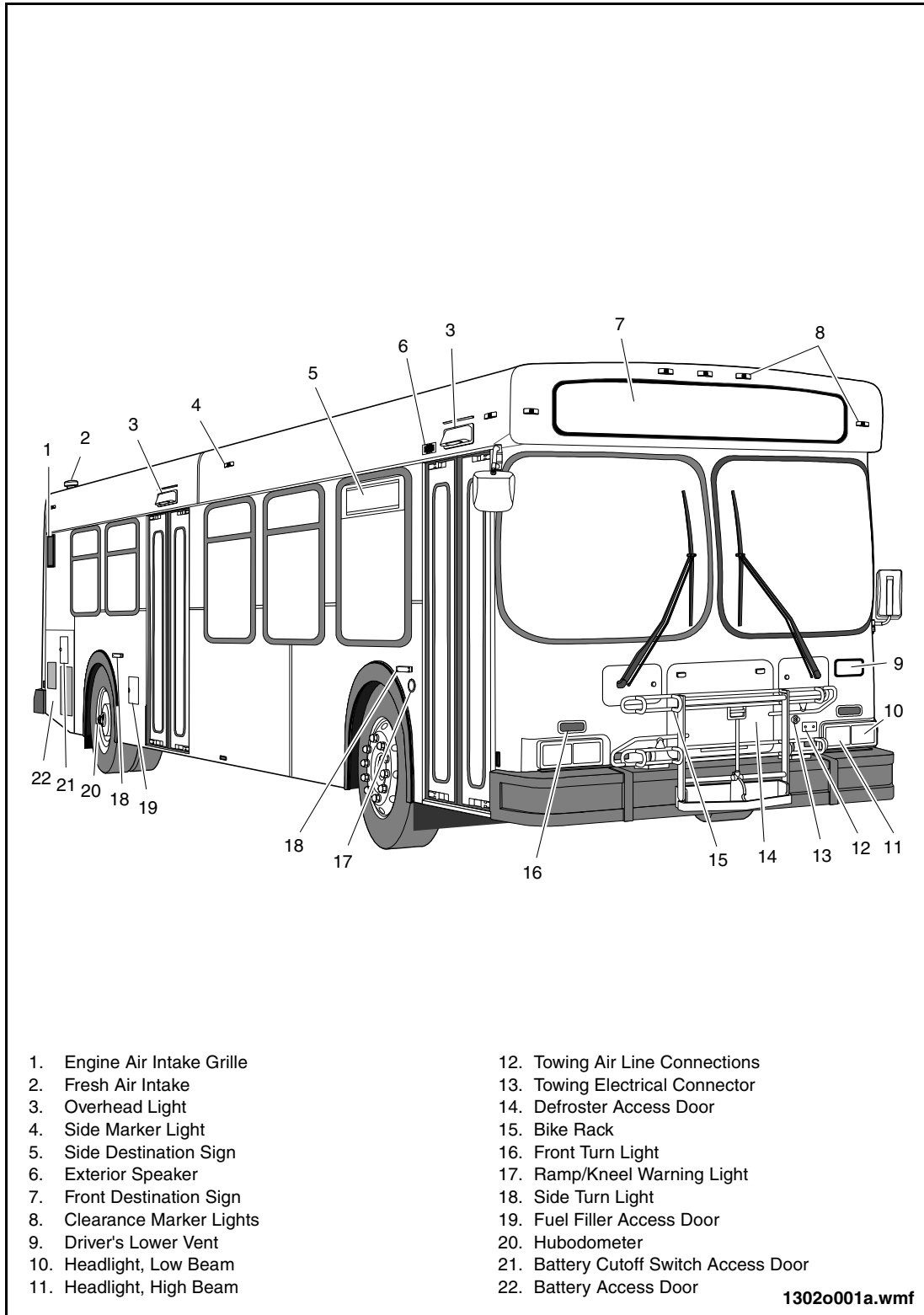

**Figure 5: Front Exterior View**

**Mirrors**

- Inspect condition of mirror housing, glass, and mounting brackets
- Check that mirror head can be easily rotated for adjustment (where applicable).

**Lights**

- Ensure all lights are clean and not obstructed in any way.
- Check that lights are securely mounted with no missing attaching hardware.
- Inspect lenses for cracks or other damage.

**Tires**

- Check tire air pressure and ensure it is within the manufacturer's recommended range.
- Inspect tire tread for abnormal wear, cuts, separation, missing tread, or any other visible defects.
- Inspect tire sidewalls for bulges, cuts, gouges, abrasions, or any other visible defects.

**Wheels**

- Check for any missing or loose wheel nuts.
- Closely inspect condition of wheel studs if any wheel nuts were found to be loose or missing.
- Visually inspect wheel for any evidence of dents, cracks, deformation, or other damage.
- Inspect wheel surface for pitting or excessive corrosion.

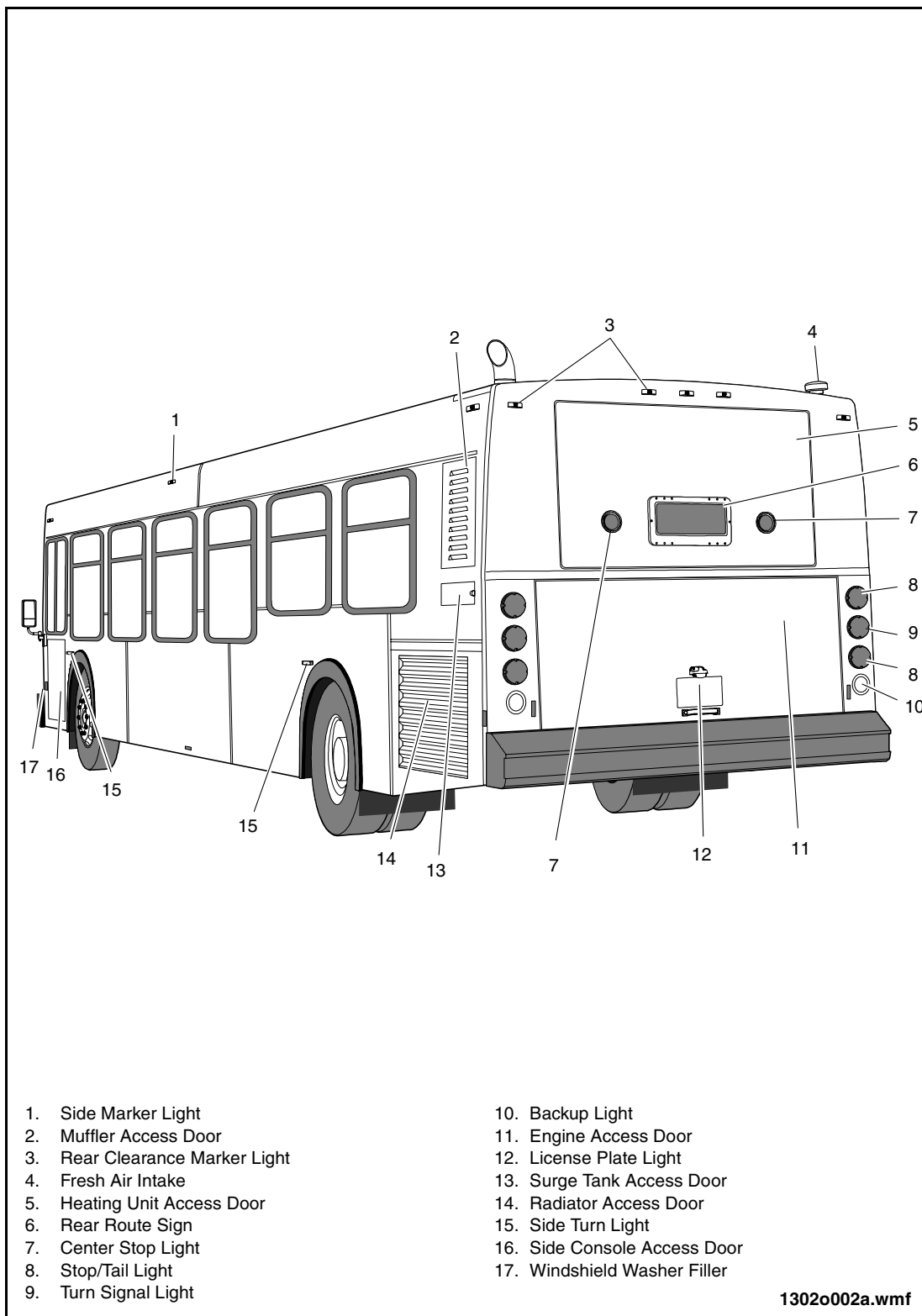

**Figure 6: Rear Exterior View**



## Interior

### General

- Ensure farebox is securely mounted and operates properly.
- Check all interior panels for any visible damage.
- Ensure front and side destination signs are securely mounted.
- Sunvisors and/or roller blinds are securely mounted and function properly.
- Check that roof hatches open in all ventilation positions and close properly.
- Ensure that roof hatches function properly in the emergency release position.
- Visually inspect condition of passenger signal system and verify operation.
- Ensure door controller moves freely through all operating positions and doors open/close accordingly.
- Door Master switch is in the ON position.
- Check that all driver's seat adjustments function properly and maintain position.
- Inspect condition of driver's seat-belt and ensure that it functions properly.
- Inspect condition of wheelchair restraint system and ensure that all mechanisms function properly.
- Check steering wheel operation with engine running. Steering should operate smoothly without binding or erratic movement.
- Check steering wheel tilt/telescope lever functions properly.
- Ensure that the wheelchair ramp functions properly and that the alarm sounds when stowing or deploying the wheelchair ramp.

### Access Doors

- Visually inspect interior door panels for any evidence of damage.
- Check that the access doors unlatch and open easily. Ensure gas struts function properly and maintain door in opened position (where applicable).
- Check for any missing or damaged rubber bumpers on the inside of the door panel.
- All access doors must be closed and securely latched (where applicable) prior to operating vehicle.

### Seats

- Ensure seats are clean and there is no evidence of cuts, tears, or other damage.
- Ensure seats are securely mounted to seat rail and floor (where applicable).



### **Floor**

- Check overall condition of flooring for cleanliness.
- Inspect flooring for any evidence of excessive wear, cuts, or other damage.
- Inspect edges of flooring and nosing for evidence of lifting or separation.
- Ensure the wheelchair ramp is fully stowed flush with the flooring surface and does not provide a tripping hazard.

### **Windows**

- Check that windows are clean and undamaged.
- Check operation of emergency release mechanism on all windows so equipped. Ensure windows release from the frame and open fully outward for emergency egress.
- Check operation of all windows equipped with slider or tilt openings. Windows should slide or tilt easily and not be loose in the frame.

### **Mirrors**

- Check condition of mirror glass for cracks or other damage.
- Ensure mirrors are securely mounted and maintain their adjusted position.
- Ensure mirrors offer a clear view and are not obstructed.

### **Passenger Doors**

- Check that doors open/close properly.
- Check door panels for dents, deformation or other damage.
- Inspect door panel glass for cleanliness and ensure glass is not cracked or otherwise damaged.
- Inspect door edges and seals for condition and proper sealing.

### **Modesty Panels/Barriers**

- Inspect condition of panels for sharp edges, cracks, or any other damage.
- Ensure panels are securely mounted to stanchions and vehicle structure.





## Stanchions & Grab Rails

- Inspect for bent or cracked tubing, rails, or any other damage.
- Ensure that all stanchions and grab rails are securely mounted.
- Inspect for any sharp edges.
- Inspect for any missing attaching hardware.
- Inspect condition and secure mounting of grab straps (where applicable).

## Lights

- Ensure all lights are clean and not obstructed in any way.
- Check that lights are securely mounted with no missing attaching hardware.
- Inspect lenses for cracks or other damage.

## Indicator Lights

### **NOTE:**

*From this point on, items on the driver's check list require activating the vehicle's Multiplexing System and starting the engine. Turning the Master Run switch on the side console to DAY-RUN or NIGHT-RUN activates the Multiplexing System. Wait for the system to activate before starting the engine. Refer to the Vehicle Operation Section of this manual for details on engine starting.*

- The Stop Request indicator illuminates when the passenger signal system is activated.
- The W/C Stop Request indicator illuminates when the wheelchair passenger signal system is activated.
- The Parking Brake indicator illuminates when the parking brake is applied.
- The Stop indicator illuminates when the brakes are applied.
- The Turn indicator illuminates and flashes when the turn signal switch is activated or the Hazard switch is turned on.
- The Rear Door Open indicator illuminates when the exit door is open.
- The High Beam indicator illuminates when the high beam headlights are on.
- The Kneel indicator illuminates when the kneeling system is activated.
- The No Gen and Stop Engine indicators illuminate momentarily, then extinguish.
- The remaining indicators relate to vehicle operation concerns and should be checked by service personnel.



## Electrical Control Systems

- The Master Run switch controls the electrical circuits. Refer to the Instrumentation & Controls Section of this manual for more information.
- Light switches, located inside the service compartments, activate the compartment lights.
- Hazard lights function with the Master Run switch in any position.
- Horn sounds when horn button on steering wheel pressed.
- Rear brake lights illuminate when the brake pedal is applied.
- Destination/route sign circuits function with the Master Run switch in DAY-RUN, NIGHT-RUN or NIGHT-PARK positions.
- All side console control switches function.
- Passenger signal and chime circuits function.
- Accelerator treadle accelerates the engine.
- Transmission Selector switch functions.
- Backup lights illuminate when the transmission is shifted to reverse.
- Heating and ventilation system functions when the engine is running.
- Speedometer functions when the vehicle is moving.

## Air Control Systems

- Normal vehicle operation pressure ranges from 105 to 125 psi (724 to 862 kPa).
- Low Air indicator illuminates and an alarm sounds if the air system pressure drops below 75 psi (517 kPa).
- Entrance and exit doors open and close smoothly.
- Windshield washers spray washer fluid onto windshield.
- Wipers operate (on wet windshield) without streaks, scraping or noisy operation.
- Brake treadle application slows and stops the vehicle smoothly.
- Parking brake valve application holds the vehicle stationary when level or on a 20% maximum incline grade when on dry concrete.
- Door manual control valve, located below the side console, shuts off the air supply to the entrance door mechanism. When in the OFF position, the doors can be pushed open.
- Splash guards clear the ground (vehicle on level surface) with the air system pressure at or above 105 psi (724 kPa).
- Compressor cuts in when the air system pressure drops to approximately 105 psi (724 kPa) and shuts off at approximately 120 to 125 psi (827 to 862 kPa).



## **5. DRIVER'S AREA**

The driver's area includes the first eight feet of interior space measured from the front windshield.

This section describes the controls and components within the driver's area. A brief outline of the functions and operating procedures of each accompanies the description.

### **Driver's Window**

#### **Front Portion**

Pull the sash handle back to open the front portion of the window. Push the handle forward to close.

#### **Aft Portion**

Pinch the sash handle to release the lock. Pull the handle forward (keeping handle pinched) to open the rear portion of the window.

Push the handle rearward, pinch and release to close and lock the aft sash.

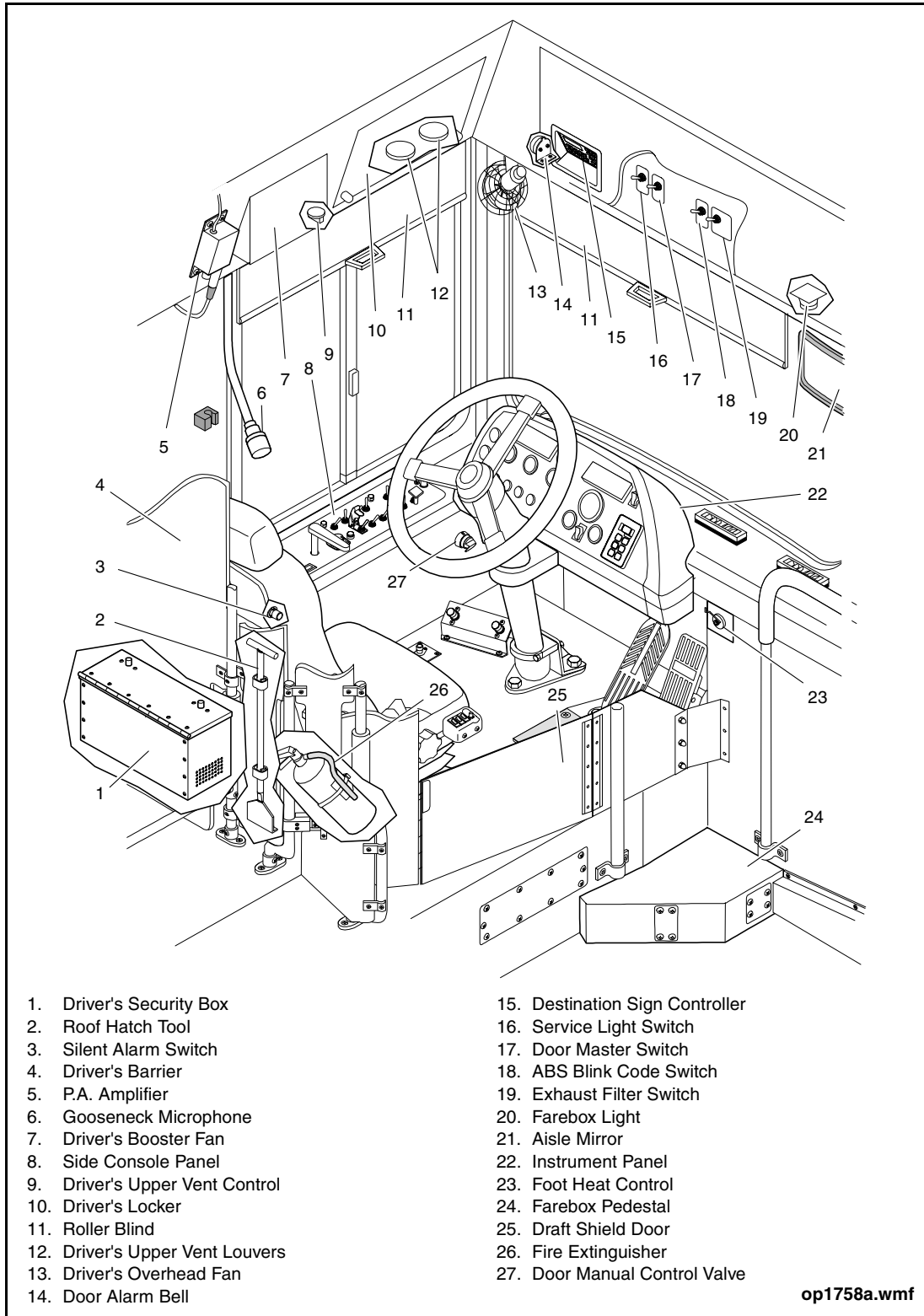

**Figure 7: Driver's Area**



## **Mirrors**

There are three mirrors located throughout the vehicle interior: an aisle mirror, an upper right mirror and a rear step area mirror.

### **Aisle Mirror**

The aisle mirror is located under the front destination sign closeout. Its convex glass surface provides a wide view of the entrance door and passenger area.

### **Upper Right Mirror**

Located to the right of the aisle mirror, the upper right mirror is used to view the rear mirror.

### **Rear Step Area Mirror**

The rear step area mirror is located on a stanchion at the exit door. It provides a view of the exit door area when looking through the upper right mirror from the driver's seat.



## Roller Blinds

There are two roller blinds in the driver's area; one for the front windshield and the other for the driver's window. The blinds can be extended or retracted by either pushing or pulling on their handles.

## Driver's Locker

Located above the driver's window and behind the driver's seat, the driver's lockers are for storing personal belongings.

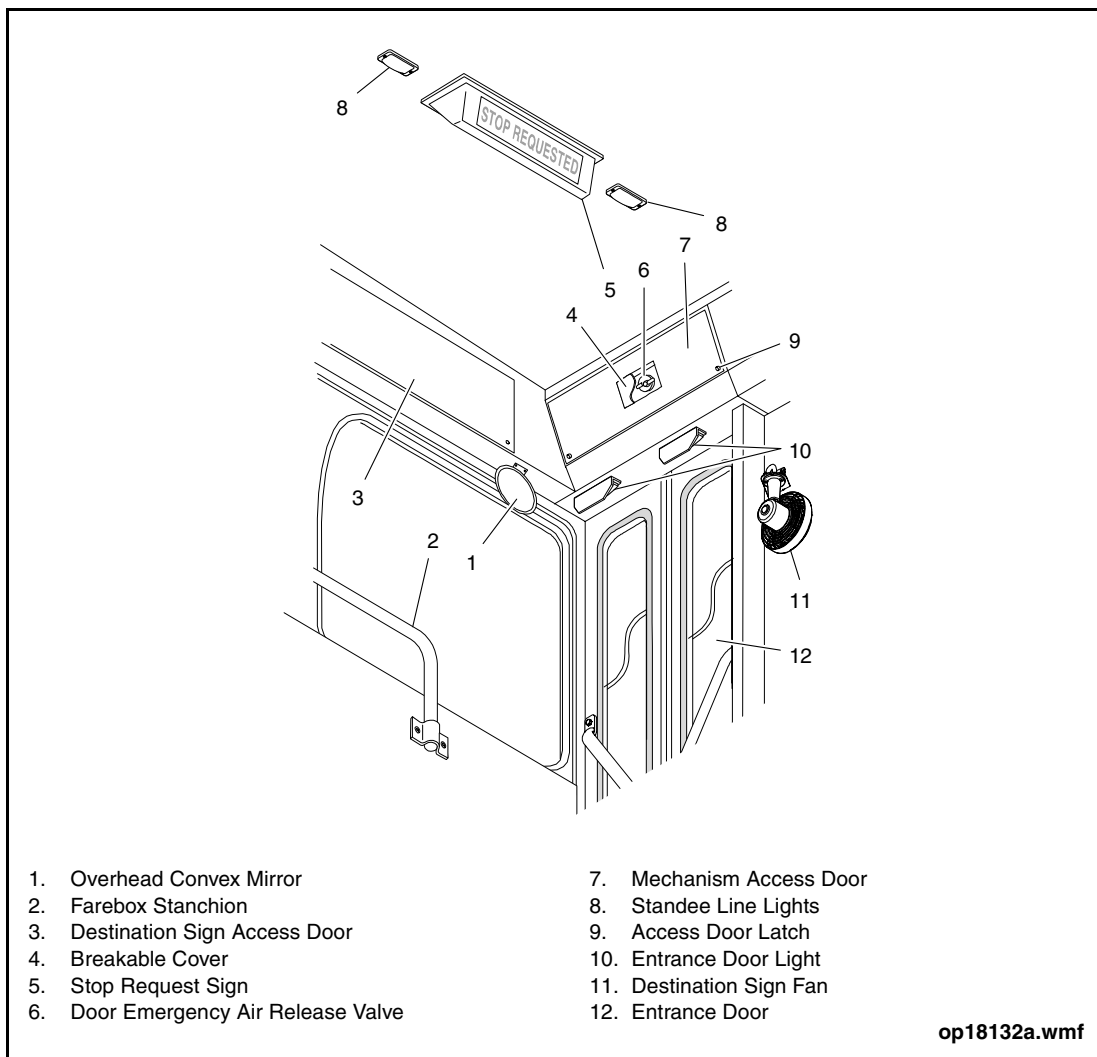

**Figure 8: Front Entrance View**



## Driver's Seat

The USSC 9100ALX driver's seat is an adjustable air suspension seat consisting of a steel frame base and back panel and molded foam cushions. The seat-belt retracts to holders beside the seat cushion.

Eight controls adjust the positioning of the seat and seat cushions to suit the needs of the individual. Make position adjustments to provide for the best driving visibility and control.

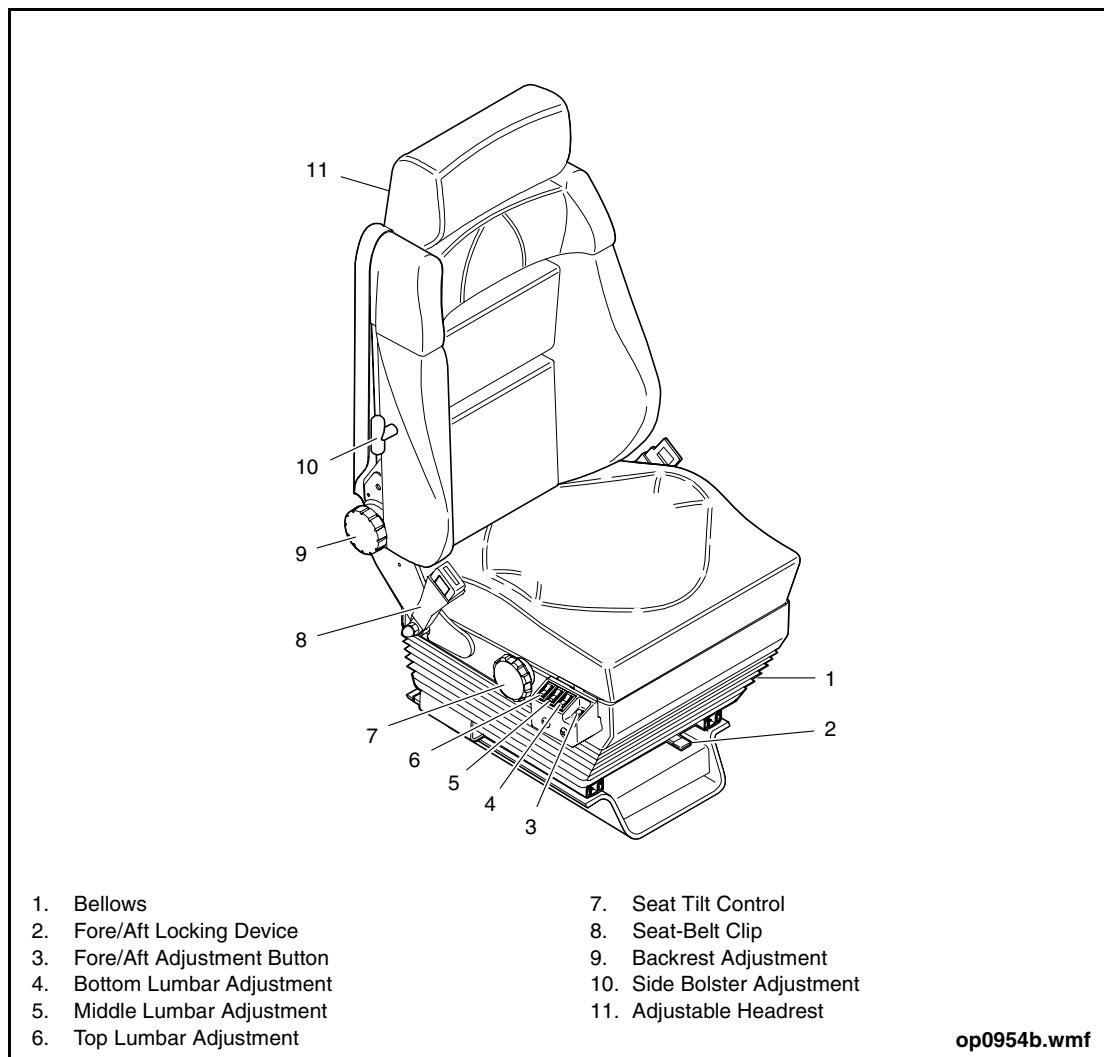

**Figure 9: Driver's Seat**



## **Lumbar & Side Bolster Adjustment**

Three rocker switches on the right side of the seat adjust the bottom, middle and top lumbar portions of the seat back. The rocker switches admit or release air pressure to three air bags in the seat back. When making adjustments, momentarily hold the switches in position to allow time for air movement. A mechanical side bolster adjustment handle on the side of the seat back allows for adjustment of the outside portion of the seat back to suit individual driver's frames.

## **Height Adjustment**

The knob on the front left corner of the seat adjusts the height. Turn the knob counter-clockwise to raise the seat and clockwise to lower it. Pull the knob out to dump air pressure and reset to the previous adjustment by pushing the knob in.

## **Tilt Adjustment**

Adjust the seat's fore and aft tilt with the large control knob on the side of the seat. Turn the knob clockwise to tilt forward and counter-clockwise to tilt rearward.

## **Fore & Aft Track Adjustment**

The fore and aft track adjustment has nine position settings. Push the button located in the right front corner of the seat to unlock and slide the seat to the desired position. Release the button and move slightly fore or aft to set lock.

## **Back Recline Adjustment**

Adjust the backrest to the desired recline position by turning the control knob located at the bottom of the backrest.

## **Suspension Lockout/Limiter Control**

Located on the left rear of the seat is a three-position lever to control seat suspension movement. The outward position allows full seat suspension movement; the middle position limits the suspension and the inward position locks the suspension.





## Steering Wheel & Horn

### Steering Wheel



**DO NOT** make adjustments to the tilt steering while the vehicle is in motion.



**DO NOT** turn the steering wheel if the engine is not operating except in emergency situations.



**DO NOT OPERATE THE VEHICLE** if any of the following conditions exist:

- **Binding or resistance in the steering wheel operation (with the vehicle in motion).**
- **Unusual noises related to steering.**
- **Steering wheel vibration.**
- **Looseness, binding or resistance in the tilt/telescopic mechanism.**



A hydraulic powered steering system turns the front wheels when moving the steering wheel left or right (the engine must be operating to power the system). The tilt/telescopic steering column offers a range of positions for the steering wheel. A lever on the left of the column controls both tilt and telescopic functions. Push to telescope and pull to tilt.

## Horn

The horn button, located in the center of the steering wheel, operates the dual horn.

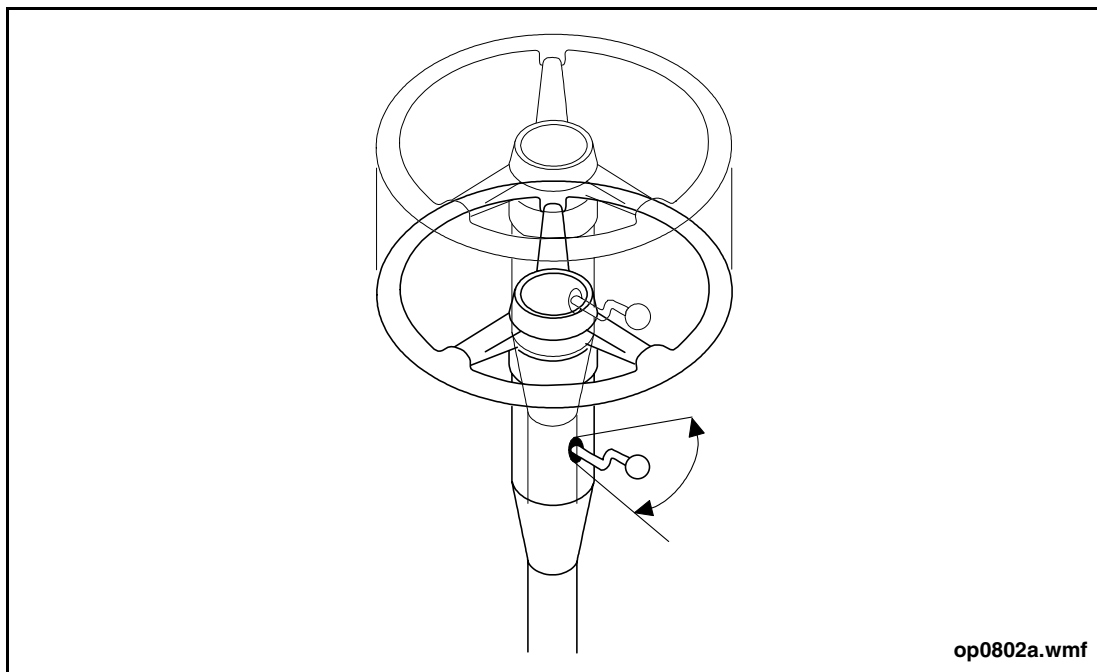

**Figure 10: Steering Wheel Adjustment**



## Public Address System

The Public Address System (P.A.) allows the communication of messages to the public both inside and outside the vehicle. Components of the system include:

- An amplifier located over the driver's window.
- A gooseneck microphone located above the side console.
- Six interior speakers located above the side windows.
- An exterior speaker located above the entrance door.

To use the system first position the Speaker Select toggle switch on the side console to operate the desired speakers. Then use the switch on the microphone to energize the amplifier before speaking.

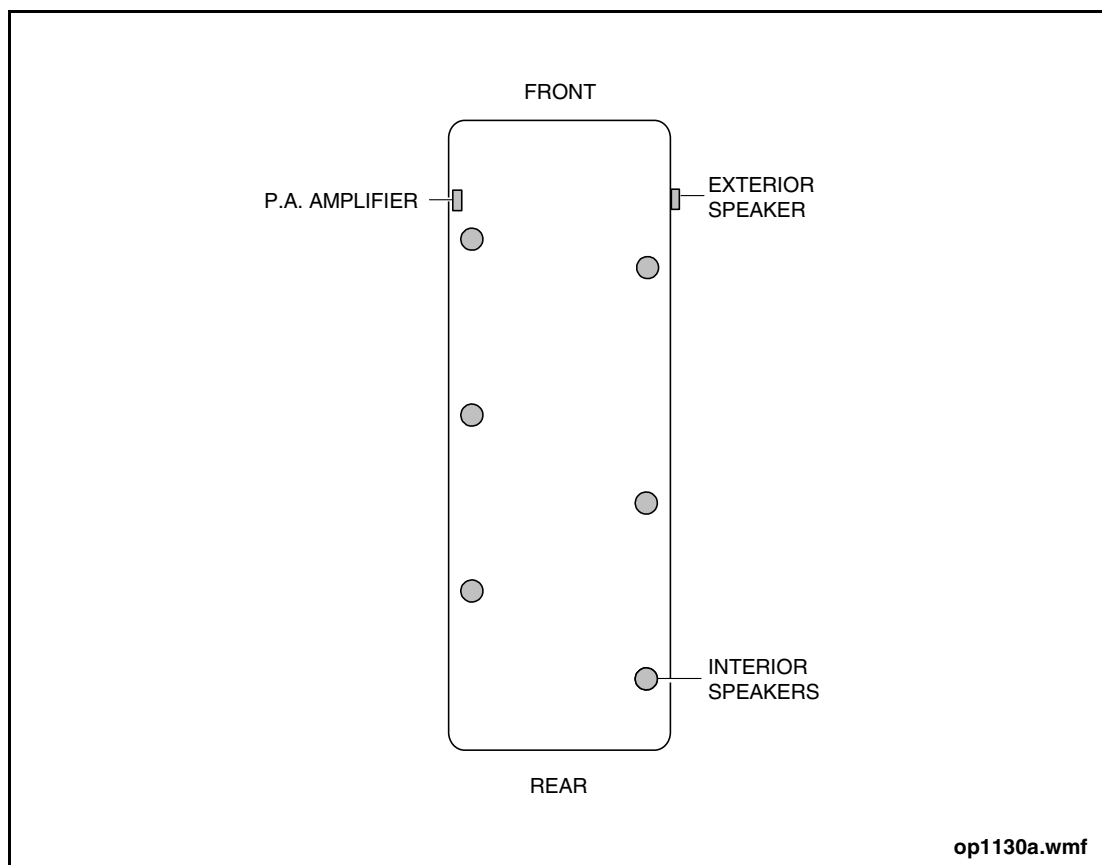

**Figure 11: P.A. System Layout**

## Destination/Route Signs

### NOTE:

*The following information provides basic introductory information on ODK and Luminator Destination Sign System operation. Your transit authority management establishes policies about system operation and should be consulted before its use. Manuals are available from Luminator which provide more information about the Operator's Display Keyboard and the Luminator Destination Sign System.*

### System Description

The vehicle's destination/route signs are controlled by an Operator's Display Keyboard (ODK) located in the panel of the front destination sign access door. The ODK functions to control and verify the destination/route sign message display.

Destination sign message codes are entered into the system data processor using the keypad switches on the front panel of the ODK. The codes translate into message writing data preprogrammed into the system's memory. The message writing data then controls the signs to display the selected information.

The system data processor begins sending and updating message writing data for the ODK to display when the system is powered-up. Turning the Master Run switch from STOP-ENGINE to DAY-RUN or NIGHT-RUN will power-up the system. Boot and application code versions momentarily display when power is applied to the ODK, followed by a brief system initialization message. The last message entered before power shutdown then displays on the ODK.

Powering-down occurs when the Master Run switch is turned to STOP-ENGINE. Upon powering-down, front and side destination signs will blank immediately or after a preset delay.

### Operating the ODK

Basic operation of the Sign System involves presetting transit authority message codes into the sign system using the ODK. The message codes correlate to preprogrammed destination names, public relations messages, and route numbers unique to each transit authority. If required, multiple sets of message codes may be entered to allow for a quick and complete sign change while in route. Key function and code entry instructions are described in the two sections that follow.



## ODK Keypad Switches

The ODK contains 28 keypad switches. Certain keypad switches, or groups, may not function if they are not needed for coded entry procedures. Switches that are not enabled either have no effect when pressed, or indicate that particular function is not available. Keypad switch functions are as follows:

- P/R - press to enable public relations message code entry.
- ROUTE - press to enable route number entry. Route number entry may be either coded or be the actual route number for display.
- DEST A, DEST B - press the appropriate key (A or B) to enable destination message code entry and/or message display change.
- 0-9 Group - key switches are for sequential entering of message codes. These keys function only after a destination (DEST A, DEST B) or enabled public relations (P/R) switch is pressed.
- A-F Group - key switches are for sequential entering of message codes that contain letters and numbers. Normally these keys will only enable if they are part of an existing message code.
- ENTER - press to activate the selected message during code entry and during operation.
- MENU - press to access advanced programming options. Consult your transit authority before use.
- SELECT - press to select additional characters G-Z when entering message code(s).
- MESSAGE TEXT - key switch is not currently in use.

 **NOTE:**

*Code entry sequences must be followed to set-up destination sign messages. A “beep” sounds and a visual read-out appears on the ODK display when pressing any enabled keypad switch.*

## Code Entry

When powering-up the sign system it will display the messages entered previously. If continuing on the same route, re-entering new codes may not be required.

To enter a new set of message codes:

1. Consult the transit authority code list for the code that corresponds to your route.
2. Press the switch DEST A, DEST B, P/R, or ROUTE for the message code you are about to enter.



3. For each code press the corresponding switches in the 0 through 9 and/or A through F groupings one at a time and in proper sequence.

**NOTE:**

*If the message code contains letter(s) G-Z, press the SELECT key for access.*

4. Press the ENTER key switch and allow the ODK to display the actual message.
5. Repeat steps 1 to 4 for each code required for the route.

To change from one preset message to another for a turn-around or while in route press the appropriate DEST A or DEST B switch.

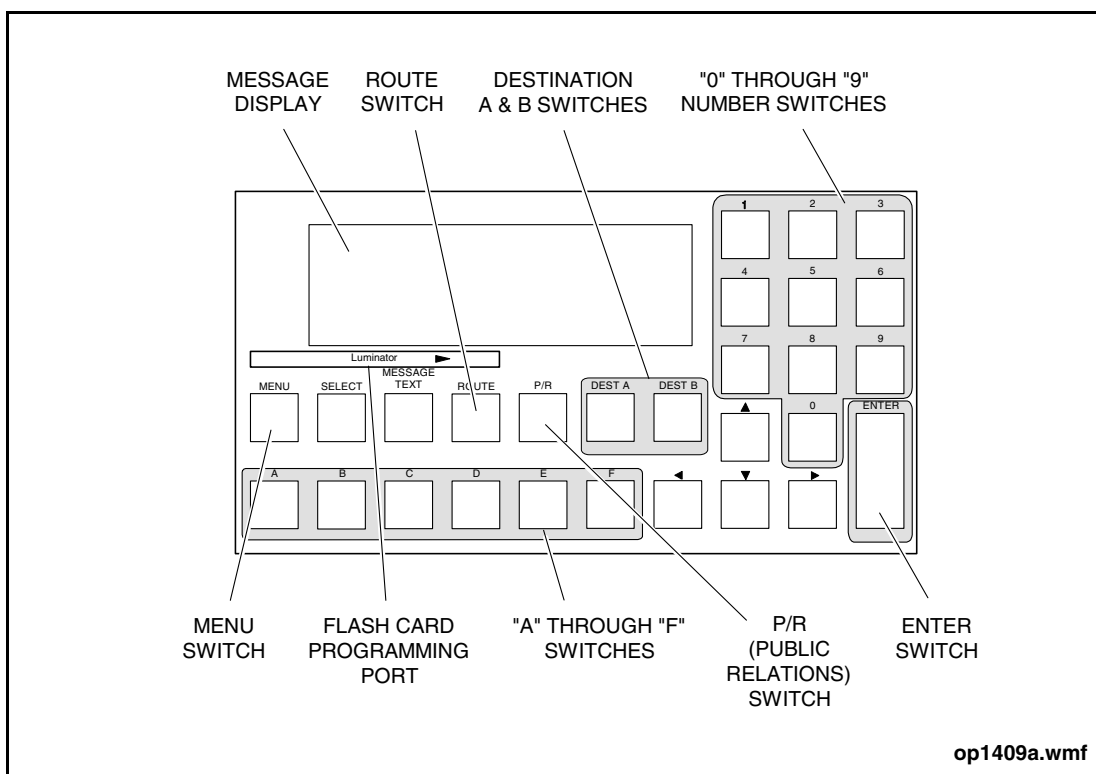

**Figure 12: Operator's Display Keyboard (ODK)**



## 6. INSTRUMENTATION & CONTROLS

### Instrument Panel

#### Turn Indicators (Green)



**WARNING:**



**If turn signal indicators do not operate as described, DO NOT OPERATE THE VEHICLE.**

The turn indicators, symbolized by directional arrows, flash on either side of the instrument panel when the right-hand or left-hand floor-mounted turn signal switch is pressed.

When the Hazard switch is activated, both turn indicators flash together. Failure of these lights to flash normally indicates that the flasher module is not functioning.

#### No Gen Indicator (Red)



**CAUTION:**



**If the no gen indicator remains illuminated while the engine is operating, DO NOT OPERATE THE VEHICLE.**

The no gen indicator, symbolized by a battery, illuminates when the alternator is not charging. The no gen indicator illuminates when the Master Run switch is in the DAY-RUN or NIGHT-RUN position and the engine is not operating. The no gen indicator turns off once the engine is operating.

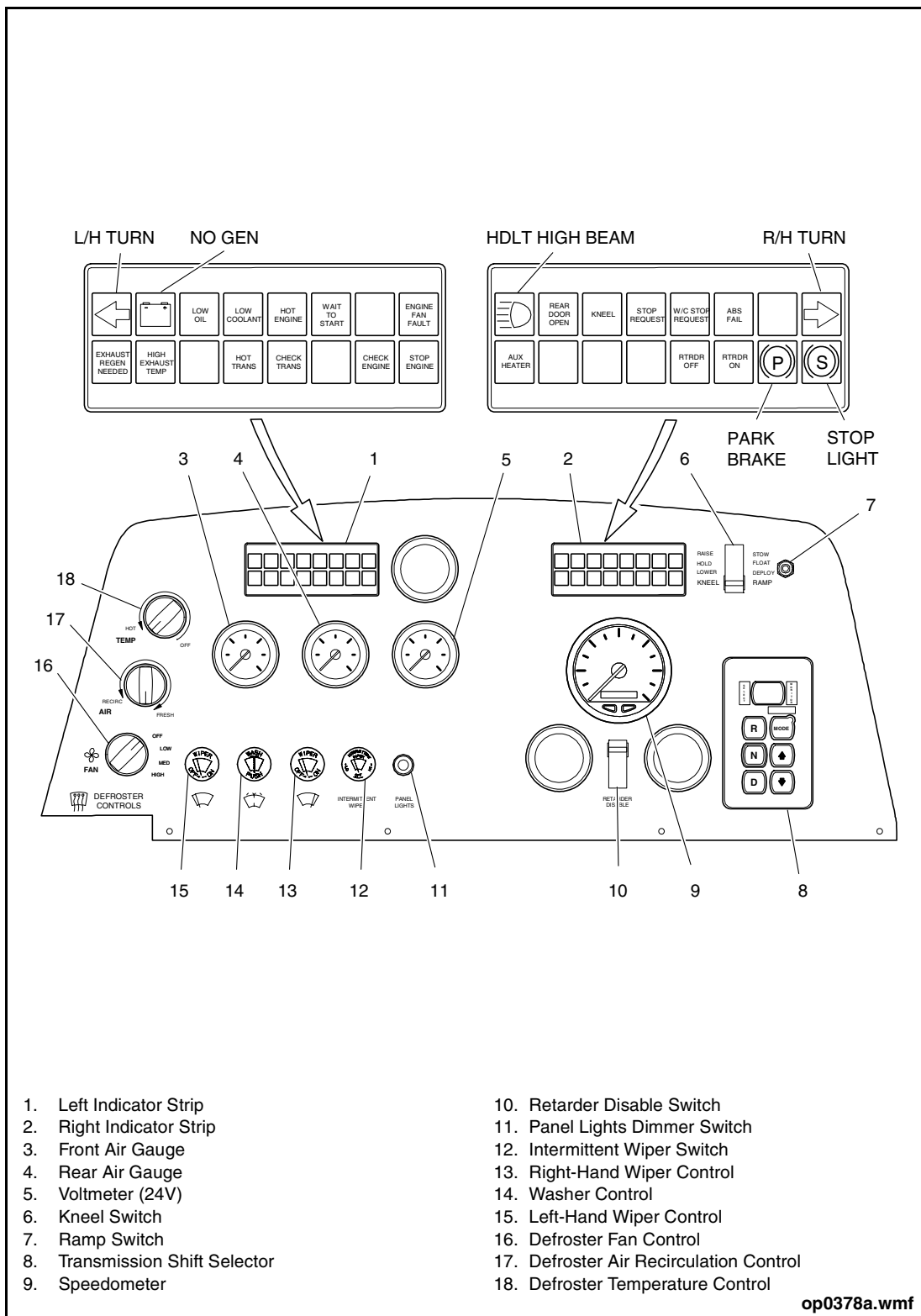

Figure 13: Instrument Panel





## Low Oil Indicator (Red)

**CAUTION:**

**If the Low Oil alarm continues and the indicator lamp remains illuminated, DO NOT OPERATE THE VEHICLE.**

The Low Oil indicator illuminates if the engine oil pressure is too low for proper engine lubrication. The Low Oil indicator is accompanied by a warning buzzer.

Before starting the engine, positioning the Master Run switch to DAY-RUN or NIGHT-RUN illuminates the Low Oil indicator and sounds its alarm. This occurs momentarily and is a normal electrical system test.

 **NOTE:**

*If this indicator remains illuminated, the Engine Protection System engages to initiate an automatic engine shutdown sequence.*

## Low Coolant Indicator (Amber)

The Low Coolant indicator illuminates if too little coolant is in the engine to maintain normal engine operating temperature.

 **NOTE:**

*If this indicator remains illuminated, the Engine Protection System engages to initiate an automatic engine shutdown sequence.*

## Hot Engine Indicator (Red)

The Hot Engine indicator will illuminate if the engine exceeds its normal operating temperature and overheats. The Hot Engine indicator is accompanied by a warning buzzer.

 **NOTE:**

*If this indicator remains illuminated, the Engine Protection System engages, initiating an automatic engine shutdown sequence.*



## Wait to Start Indicator (Amber)

The Wait to Start indicator illuminates before engine start-up with the Master Run switch in the DAY-RUN or NIGHT-RUN position. The indicator will remain illuminated for up to 45 seconds while the intake air heater system operates.



### NOTE:

*The Wait to Start indicator and the intake air heater system will only operate in temperatures below 66°F (19°C).*

## Engine Fan Fault (Amber)

The Engine Fan Fault indicator will illuminate if a fault is detected with the fan drive cooling system. A low hydraulic fluid level signal, a plugged hydraulic fluid filter, or a hi-speed fan with engine cold condition will register as a fault. Notify maintenance personnel if this indicator illuminates.

## Exhaust Regen Needed Indicator (Amber)

This indicator illuminates when the engine ECU receives a thermal signal from the muffler sensor indicating that the muffler filter requires a regenerative cycle. Notify service personnel when this occurs.

## High Exhaust Temp Indicator (Amber)



**WARNING:**



**If the High Exhaust Temp indicator on the instrument panel illuminates, ensure the exhaust outlet is not located where it could cause damage to persons or any materials which could melt or explode, and that nothing is within 2 feet of the outlet. Ensure no combustible materials are within 5 feet of the outlet. Exhaust outlet temperatures can reach 1500°F (800°C) when this indicator illuminates.**

This indicator illuminates when the muffler thermocouple detects a temperature higher than normal operating conditions. Notify service personnel when this occurs.



### Hot Trans Indicator (Red)

**CAUTION:**

**If the Hot Transmission indicator illuminates for more than 30 seconds, remove the vehicle from traffic to a safe location, shut the engine down and apply the parking brake.**

The Hot Transmission indicator is wired to the transmission control system. This indicator illuminates and a warning buzzer sounds if the temperature sensors detect overheated transmission fluid.

### Check Trans Indicator (Red)

The Check Trans indicator illuminates if the Electronic Control Unit (ECU) has detected a potentially serious problem in the transmission. If this indicator illuminates, **DO NOT OPERATE THE VEHICLE.**

### Check Engine Indicator (Amber)

**CAUTION:**

**If after engine start-up the Check Engine indicator remains illuminated, advise service personnel. Avoid extended periods of operation with this indicator illuminated.**

The Check Engine indicator illuminates if the engine requires service. The indicator is controlled by the vehicle's Multiplexing System which monitors engine sensor output. The Multiplexing System will illuminate the indicator if sensor output signals fall outside of a predetermined range.

### Stop Engine Indicator (Red)

The Stop Engine indicator illuminates if an engine operating condition occurs that will result in damage to the engine. The indicator is controlled by the vehicle's Multiplexing System which monitors engine sensor output. If the Multiplexing System illuminates the indicator it also initiates an engine shut-down sequence.

As an operation check, the Stop Engine indicator should remain illuminated momentarily when the engine is started.



 **NOTE:**

*If this indicator remains illuminated, the engine will continue running for 30 seconds. Use the time to drive out of traffic to a safe area.*

### High Beam Indicator (Blue)

The high beam indicator, symbolized by a lit headlight, illuminates when the vehicle headlights are in the high beam mode of operation. Pressing the dimmer switch returns the headlights to normal low beam operation.

### Rear Door Open Indicator (Red)

The Rear Door Open indicator illuminates under the following conditions:

- The door controller is turned to position #3, #4 or #5
- The exit doors are open.
- The door master switch is in the off position.
- The rear door emergency control is activated.
- The sensitive edge is touched with the door partly open.

### Kneel Indicator (Amber)

The Kneel indicator illuminates when the front suspension is in the kneeling mode and is lowering the vehicle to the curb.

 **NOTE:**

*The Kneel toggle switch is on the instrument panel.*

### Stop Request Indicator (Red)

The Stop Request indicator illuminates when the passenger signal system has been activated.

### W/C Stop Request Indicator (Amber)

The Wheelchair Stop Request indicator illuminates when the wheelchair passenger signal system has been activated.



### **ABS Fail Indicator (Amber)**

The ABS Fail indicator illuminates if the ABS System requires service. Engine start-up illuminates the indicator momentarily as part of a system check. It is also used during diagnostics to display the blink code. Refer to the Vehicle Operation Section of this manual for more information on this system.

### **Aux Heater Indicator (Amber)**

The Auxiliary Heater indicator illuminates when the engine auxiliary coolant heater functions. It starts automatically in cold conditions to heat the engine coolant to operating temperature.

 **NOTE:**

*The heater operates only with the Master Run switch in either the DAY-RUN or NIGHT-RUN position.*

### **Retarder Off Indicator (Red)**

The Retarder Off indicator illuminates to indicate that the Retarder Disable switch on the instrument panel is in the OFF position disconnecting power from the transmission retarder.

### **Retarder On Indicator (Amber)**

The Retarder On indicator illuminates to indicate operation of the transmission retarder.

### **Parking Brake Indicator (Red)**

The parking brake indicator, symbolized by a circled letter P, illuminates when the parking brake control valve is applied. Activating the parking brake illuminates the stop lights indicator and all red stop lamps.

## Stop Lights Indicator (Red)



**WARNING:**



**If the stop lights indicator does not operate as described, DO NOT OPERATE THE VEHICLE.**

The stop lights indicator, symbolized by a circled letter S, illuminates each time the service brake or parking brake control valve is applied. If under these circumstances the indicator does not illuminate, then any or all rear stop lights are malfunctioning.

## Air Pressure Gauges

Individual analog air pressure gauges are used to monitor the vehicle's front and rear air brake systems. An LED indicator at the bottom of the gauge illuminates and a warning buzzer sounds if air pressure drops below 75 psi (483 kPa). If air pressure exceeds the normal operating range, the LED indicator will flash. Normal operating pressure range is 105 to 125 psi (724 to 862 kPa).

 **NOTE:**

*The analog-driven gauges will indicate current values and the warning LED indicators in the data gauges will flash if the Master Run switch remains in the DAY-RUN or NIGHT-RUN position without the vehicle being started.*

## Voltmeter (24V)

The voltmeter indicates the voltage levels in the vehicle's 24 volt electrical system. The normal operating range is between 23 and 28 volts.

 **NOTE:**

*Notify service personnel if the readings fall outside of this range.*



## Kneel Switch



**CAUTION:**



**When placed in the RAISE position, the Kneel toggle switch will latch and continue to raise the vehicle until full ride height is reached at which point the raising action will automatically stop. In order to interrupt the raising operation during its cycle, the toggle switch must be set to the HOLD position.**

This three-position momentary switch is used to operate the vehicle's kneeling system. The kneeling system lowers the front of the vehicle approximately 3 to 4 inches by exhausting air from both front suspension air springs. Boarding the vehicle becomes easier, particularly for small children and the handicapped.

### **LOWER**

This position lowers the vehicle, activating the interlocks, the audible alarm and the exterior warning light. The instrument panel Kneel indicator also illuminates.

 **NOTE:**

*The Kneel toggle switch is a momentary spring loaded switch that will operate in the LOWER position only as long as pressure on the switch is maintained.*

### **RAISE**

This position raises the vehicle automatically to its full ride height. Once the vehicle has reached normal ride height, the interlocks will release (with doors closed), the alarm will silence and the exterior warning light and Kneel indicator will both extinguish.

 **NOTE:**

*Closing the switch guard locks the switch in the RAISE position.*

### **HOLD**

During the kneeling cycle, this position stops kneeling operations, silences the alarms and extinguishes the exterior warning light. The Kneel indicator and the interlocks remain activated.

## Ramp Switch



**CAUTION:**



**The Ramp toggle switch is a momentary type. If pressure is removed, the switch returns to the center FLOAT position and operation ceases.**

This is a three-position switch that controls the wheelchair ramp.

### DEPLOY

This position activates the ramp from the closed position to the open position.

### FLOAT

This position shuts off power to the pump, allowing the ramp to free-fall to either the open or the closed position. Upon cycle completion this becomes an off position.

### STOW

This position is used to move the ramp from the open to the closed position.

Refer to Wheelchair System Section of this manual for operating procedures.

## Transmission Shift Selector



**CAUTION:**



**In temperatures below -20°F (-29°C), set the Idle Speed switch on the side console to FAST to warm the transmission. Reset the switch to NORMAL before shifting from neutral [N], to reverse [R] or drive [D].**



**CAUTION:**



**Be sure to bring the vehicle to a full stop before shifting from drive [D] to reverse [R] or vice versa.**





The transmission shift selector is located on the right-hand side of the instrument panel. The shift selector module has six push button switches and an LED display. Three switches control the reverse [R], neutral [N] and drive [D] transmission selections. The other switches are MODE, UP arrow and DOWN arrow. Refer to the Vehicle Operation Section of this manual for operational information on the shift selector.

**NOTE:**

*A backup alarm activates when reverse [R] is selected.*

## Speedometer/Odometer

This gauge indicates the vehicle's forward speed and displays the distance travelled. The digital display can be used as a standard odometer or as a trip odometer with trip-1 and trip-2 functions. It can also be set to display operating hours. The mode and set buttons below the display are used to select the desired function. The speedometer will initialize as soon as the Master Run switch is set to the DAY-RUN or NIGHT-RUN position. During this self-test process all gauges will sweep to zero points, the speedometer display panel will display all alphanumeric segments, and all indicators on the left-hand and right-hand indicator strip will illuminate momentarily.

## Retarder Disable Switch

The Retarder Disable toggle switch is a guarded switch that controls power to the retarder. Lifting the switch guard and positioning the switch up cuts off power to the retarder and illuminates the Retarder Off indicator. Lowering the switch guard pushes the switch back down to enable the retarder.

**NOTE**

*Consult your transit authority for specific operating conditions during which the Retarder Disable switch should be used.*

## Panel Lights Dimmer Switch

The Panel Lights Dimmer switch controls the brightness of the instrument and the side console panel lighting. Rotating the dimmer knob clockwise increases the brightness and counter-clockwise decreases the brightness of the panel lights.



## Intermittent Wiper Switch

The Intermittent Wiper switch allows setting a delay of the wiper sweep in times of light rain. For best results set the wiper control valves at high speed when using intermittent wipers.

## Wiper Controls

Two wiper control valves (on left side of instrument panel) operate the left-hand and right-hand wiper motors by turning the respective control knob.

## Washer Control

The washer control valve operates the windshield washer/spray system. Pushing down on the knob causes the fluid to spray onto the windshield.



### **NOTE:**

*The windshield washer bottle filler is located near the left headlight.*

## Driver's Climate Controls

### Defroster Fan Control

The defroster Fan knob on the instrument panel controls the speed of the driver's heater/defroster fan. Turning the knob from the extreme left (OFF position) to the right provides three fan speed settings: LOW, MEDIUM and HIGH.

### Defroster Air Recirculation Control

The Air knob on the instrument panel controls the amount of fresh air circulated through the driver's heater/defroster system. This knob can be set to recirculate all or a portion of air entering the heater compartment and admit a corresponding amount of fresh air.



### Defroster Temperature Control

The Temp knob on the instrument panel controls the temperature of the air blowing from the defroster. Turn the knob from left to right to decrease temperature and from right to left to increase temperature.

### Driver's Vents

The vehicle is equipped with upper and lower vents that allow outside air to enter the vehicle interior during forward motion. The lower vent inlet is located on the left front corner below the windshield and the upper vent inlet is located in the top left corner above the windshield.

The lower vent is a foot-operated vent that is controlled by a bar located forward and left of the steering column. To open the vent, push with the left foot and pull to close.

The upper vent consists of two adjustable louvered openings directly above the driver's window. A rotary control knob located slightly aft of the vents controls the opening and closing of the vents.

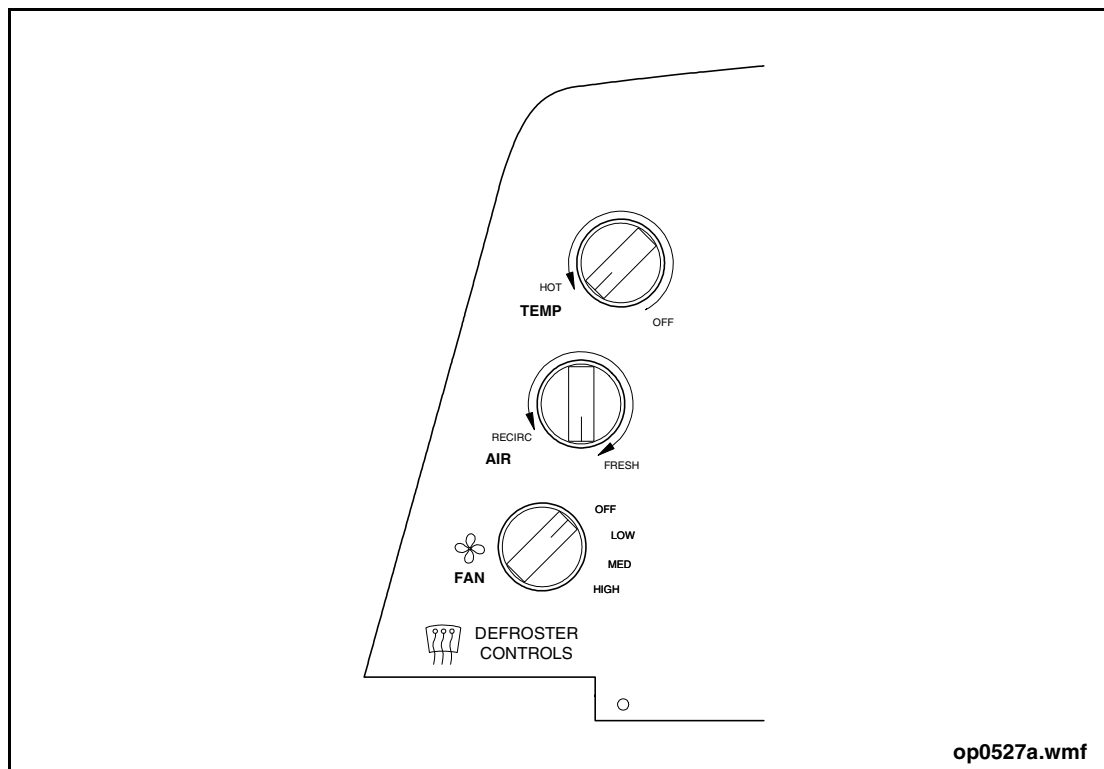

**Figure 14: Driver's Area Climate Controls**



### Driver's Foot Heat

This control lever is located on the front panel to the right of the instrument panel. It regulates air from the defroster to the foot control area. Moving the lever from its highest position down, gradually increases air flow.



**NOTE:**

*Use the Temperature control knob on the instrument panel to set the foot heat air temperature.*

### Driver's Booster Fan

Located above the side window, the driver's booster fan draws air from the vehicle's streetside air duct. A knob on the assembly provides variable fan speed control and a movable flap directs the air flow.

## Side Console Switch Panel

### Sweeper Switch

The Sweeper switch is a momentary toggle switch that controls power to four interior fluorescent lights when the vehicle is shutdown. Positioning the switch to the HOLD position will illuminate the second and fourth lights on both sides of the vehicle interior. A timer will automatically extinguish the lights after 10 minutes.



**NOTE:**

*The exit door can be opened during the first two minutes of Sweeper switch operation, after which the exit door will automatically be disabled.*



## Stop Engine Override Switch

**WARNING:**

**Apply the Stop Engine Override switch only for emergencies, such as moving the vehicle from traffic to a safe stopping area. The override interval is 30 seconds. Repeat the switch cycle to activate a repeat override sequence, if necessary.**

The Stop Engine Override toggle switch is used to override the engine shutdown system in an emergency. Refer to Vehicle Operation Section of this manual for more information.

## Hill Start Switch

The Hill Start switch is a momentary toggle switch that operates the vehicle's brakes to prevent unwanted motion when starting on a hill. Position and hold the switch to ON to apply the brakes. Release the switch when the transmission system torque can move the vehicle in the desired direction.

## Speaker Select Switch

The Speaker Select toggle switch controls the interior and exterior speakers of the public address (P.A.) system. Position this toggle switch to INSIDE, OUTSIDE or BOTH to direct the P.A. announcement to the desired audience.

## Layover Signal Switch

The Layover Signal toggle switch controls the curbside (right) turn indicator lights. Position the switch to ON and only these lights will flash the at regular intervals.

## Dash Fan Switch

The Dash Fan toggle switch controls the driver's fan mounted beneath the destination sign panel. To run the fan, reposition switch from OFF to either HIGH or LOW for desired speed.

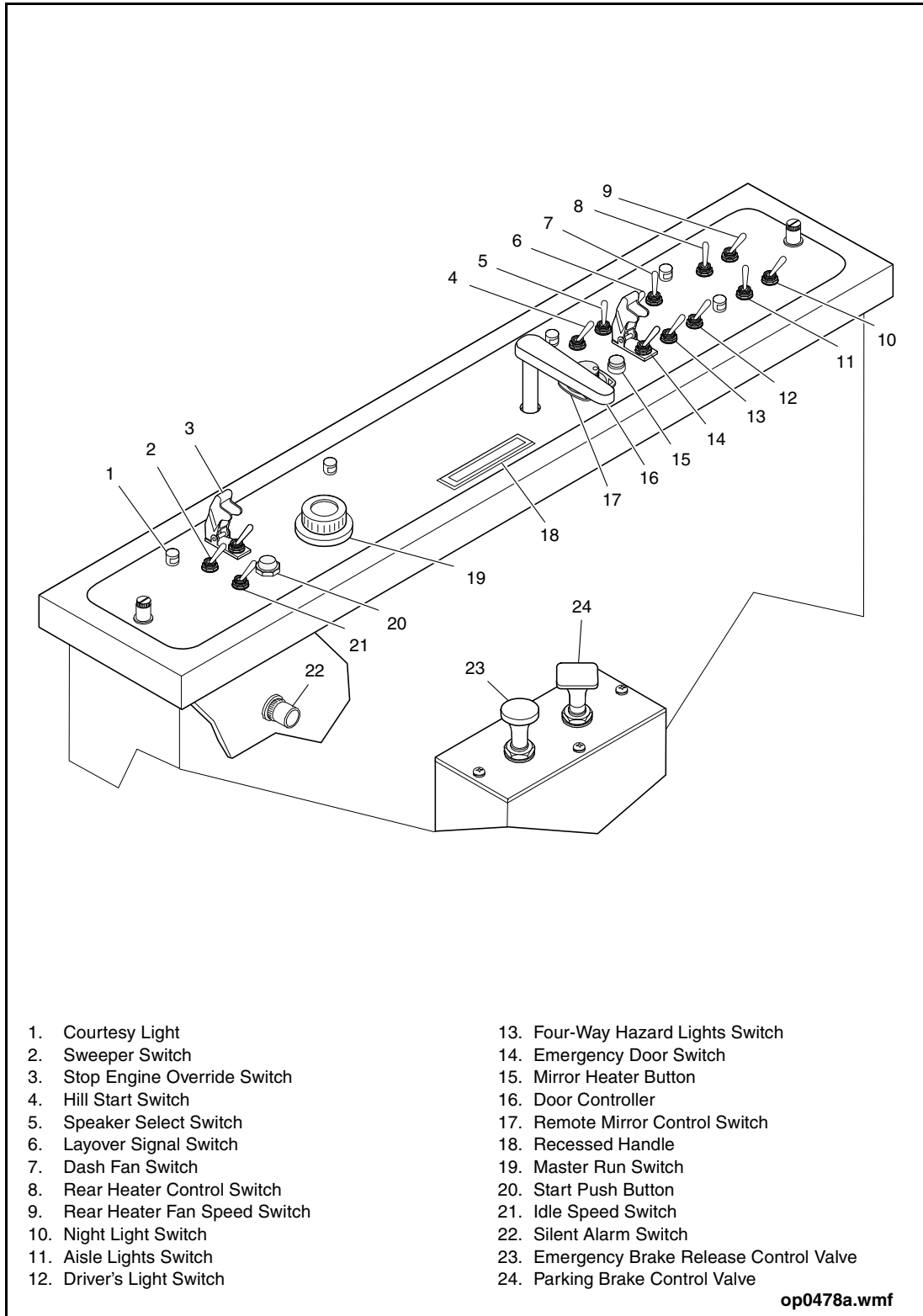

**Figure 15: Side Console Panel**



### **Rear Heater Control Switch**

The Rear Heater Control toggle switch is a three-position toggle switch that controls the heating system. In the HEAT position, the system will maintain a preset temperature. In the VENT position, the main rear unit operates to draw fresh air into the vehicle. The OFF position deactivates the system.

### **Rear Heater Fan Speed Switch**

The Rear Heater Fan Speed toggle switch controls the fan speed of the main heater unit. Position switch to either HIGH or LOW for a desired speed.

### **Night Light Switch**

The Night Light toggle switch controls power to the interior fluorescent light panels that are operational when Aisle Lights switch is in either the NORMAL or the ON position. Selecting the Night Light switch “A” position turns on certain aisle lights, and positioning the switch to “B” extinguishes the lights. Refer to the Aisle Lights Switch Operation chart for specific operating conditions.

### **Aisle Lights Switch**

The following table displays the lights that will be illuminated based on the positions of the Aisle Lights switch and Master Run switch.

<b>AISLE LIGHTS SWITCH OPERATION</b>			
<b>AISLE LIGHTS SWITCH POSITION</b>	<b>MASTER RUN SWITCH POSITION</b>	<b>NIGHT LIGHT SWITCH POSITION</b>	<b>ILLUMINATED LIGHTS</b>
ON	DAY-RUN	A	Streetside (1,2,3,4,5) Curbside (1,2,3,4,5)
ON	NIGHT-RUN	A	Streetside (1,2,3,4,5) Curbside (1,2,3,4,5)
ON	NIGHT-PARK	A,B	Streetside (None) Curbside (None)
NORMAL	DAY-RUN	A	Streetside (3,5) Curbside (3,5)



<b>AISLE LIGHTS SWITCH OPERATION</b>			
<b>AISLE LIGHTS SWITCH POSITION</b>	<b>MASTER RUN SWITCH POSITION</b>	<b>NIGHT LIGHT SWITCH POSITION</b>	<b>ILLUMINATED LIGHTS</b>
NORMAL	NIGHT-RUN	A	Streetside (3,5) Curbside (3,5)
NORMAL	NIGHT-PARK*	A,B	Streetside (None) Curbside (None)
OFF	ANY POSITION	A,B	Streetside (None) Curbside (None)

\* Aisle lights will automatically shut off after 10 minutes.

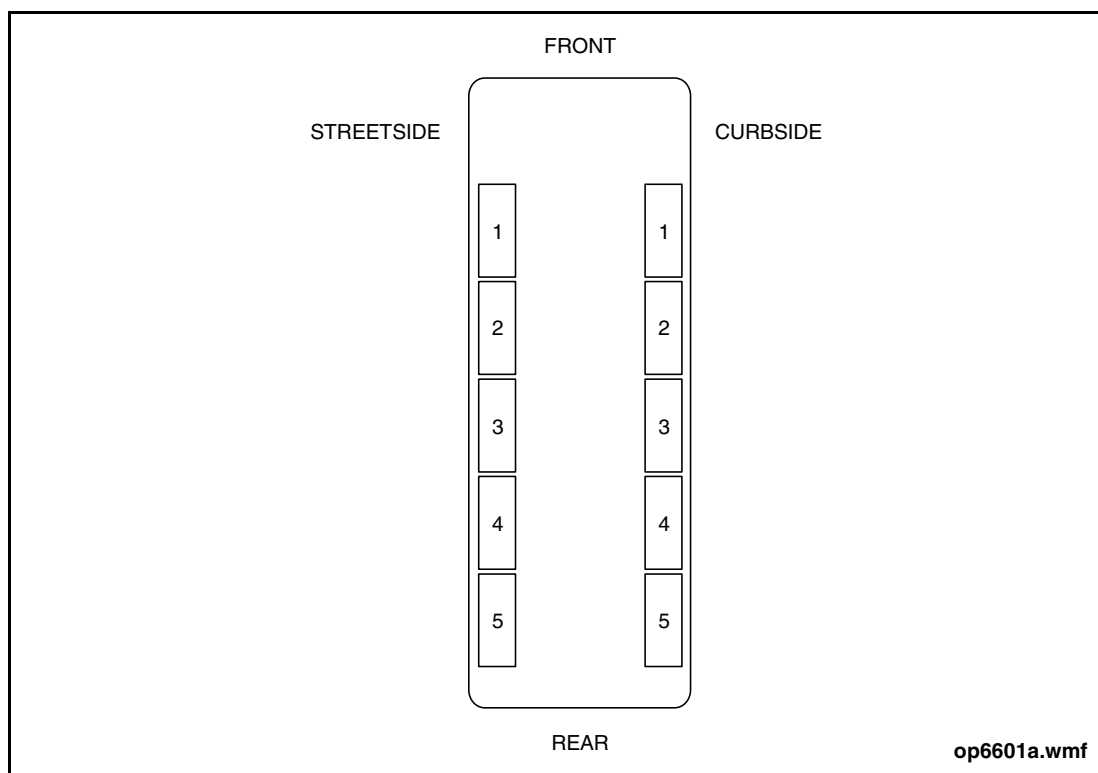

**Figure 16: Interior Lighting Panels**





### **Driver's Light Switch**

The Driver's Light toggle switch is a two-position switch that controls the light above the driver.

### **Four-Way Hazard Lights Switch**

The Four-Way Hazard Lights toggle switch has an ON and OFF position. When the switch is ON, the instrument panel turn indicators and the exterior signal lights flash.

When the switch is OFF, the exterior signal lights function only as turn signals. The exterior signal lights and instrument panel turn indicators flash when the left or right turn signal foot-switch is pushed and held.

Activate the four-way hazard lights when the transit vehicle is stopped or parked in an area and may block traffic or present a possible hazard to following or approaching vehicles. Also use the four-way hazard lights when the vehicle is being towed.

### **Emergency Door Switch**

This is a guarded toggle switch that allows operation of the rear exit door separate from the door controller. Lifting the switch guard up and positioning the switch to ON will open the rear exit door. Lowering the switch guard returns the switch to OFF for normal door controller function.

### **Mirror Heater Button**

This push button powers the heater elements behind the right and left exterior mirrors. The button illuminates to confirm heater element operation.



## Door Controller



**WARNING:**



**Positioning the Door Master switch to OFF disables the brake interlocks and the exit door controller.**

The door controller opens and closes the entrance and exit doors. The five positions of the controller and the related door functions are as follows:

- Position #1: Entrance door closed, exit doors disabled.
- Position #2: Entrance door open, exit doors disabled.
- Position #3: Entrance door open, exit doors open.
- Position #4: Entrance door closed, exit doors open.
- Position #5: Entrance door open, exit doors open.

When the entrance or exit door is open, the brake and accelerator interlocks apply automatically and the stop lights indicator illuminates.

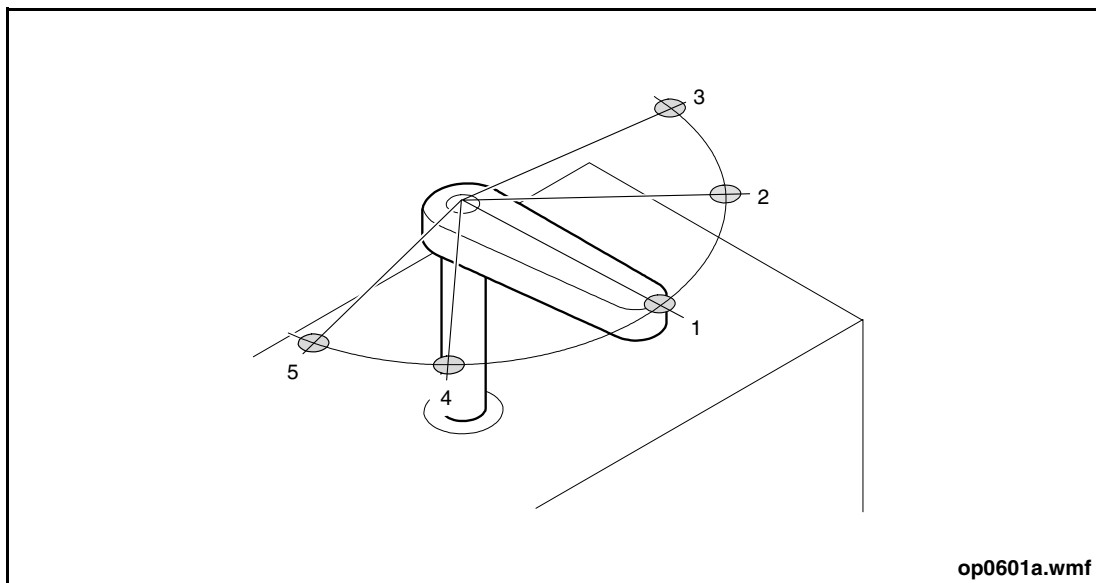

**Figure 17: Door Controller**



### Remote Mirror Control Switch

The Remote Mirror Control switch allows the operator to adjust the curbside mirror from the driver's seat.

### Master Run Switch

The Master Run Switch is a 4-position rotary switch. The DAY-RUN, NIGHT-RUN, and NIGHT PARK positions are used to activate the vehicle Multiplexing System and energize various 12/24V electrical circuits. The STOP-ENGINE position is used to shutdown the engine and de-energize the Multiplexing System and most 12/24V electrical circuits except those associated with safety functions. The Battery Disconnect switch must be set to the OFF position in order to disconnect the remaining 12/24V circuits from the vehicle batteries. The following table provides a list of circuits energized by the various Master Run switch positions:

**NOTE:**  
*The Multiplexing System is programmed to remain active for 30 minutes after the Master Run Switch is set to the STOP-ENGINE position.*

<b>MASTER RUN SWITCH OPERATION</b>				
<b>CIRCUIT OR SYSTEM</b>	<b>STOP-ENGINE</b>	<b>DAY-RUN</b>	<b>NIGHT-RUN</b>	<b>NIGHT-PARK</b>
Daytime running lights		x		
Headlights (high & low beam)			x	
Four-way hazard lights	x	x	x	x
Turn lights***	x	x	x	x
Stop lights		x	x	
Clearance/marker lights			x	x
Tail lights			x	x
License plate light			x	x
Backup lights & alarm*		x	x	
Aisle lights (normal)		x	x	
Aisle lights (on)***		x	x	

**MASTER RUN SWITCH OPERATION**

<b>CIRCUIT OR SYSTEM</b>	<b>STOP-ENGINE</b>	<b>DAY-RUN</b>	<b>NIGHT-RUN</b>	<b>NIGHT-PARK</b>
Sweeper lights	x			
Instrument panel illumination			x	x
Instrument panel dimmer			x	x
Driver's lamp***	x	x	x	x
Service compartment lights***	x	x	x	x
Entrance & exit door lights with door open **		x	x	x
Instrument panel warning indicators		x	x	
Transmission shift selector		x	x	
Brake & accelerator interlocks		x	x	
Destination sign operation		x	x	x
Door controller		x	x	x
Horns	x	x	x	x
Retarder *		x	x	
Driver's alarm		x	x	
Parking brake alarm***	x			x
Silent alarm		x	x	x
Kneeling operation & alarm		x	x	
Wheelchair ramp & alarm		x	x	x
Passenger signal system		x	x	
Public address system		x	x	
Heating & ventilating system *		x	x	
Auxiliary heater		x	x	
Intermittent wiper control		x	x	
Remote mirrors		x	x	
Heated mirrors		x	x	

\* Engine must be running

\*\* DAY-RUN also requires W/C ramp deployed

\*\*\*Multiplexing system must be active



## Start Push Button

**WARNING:**

**Put the shift selector in neutral [N] and apply the parking brake before starting the engine. If the parking brake indicator does not illuminate, DO NOT OPERATE THE VEHICLE.**

This momentary push button on the side console allows the operator to start the engine without leaving the driver's seat.

**NOTE:**

*The Multiplexing System limits continuous starter operation to 14 seconds; the starter circuit is then disconnected for 60 seconds to allow the starter to cool down.*

## Idle Speed Switch

**CAUTION:**

**Excessive engine idling is not recommended by the engine manufacturer. Operate engine at fast idle speed if idling for periods longer than 10 minutes. Consult your local transit authority for operating policy.**

The Idle Speed toggle switch activates the preset fast idle to increase the engine RPM to maintain optimum engine operating temperature during periods of extended idling. Activating the fast idle following a cold engine start also allows quicker engine warm-up.

**NOTE:**

*The FAST position on the Idle Speed switch only operates if the engine is running, the transmission shift selector is in the neutral [N] position and the parking brake is applied.*

## Silent Alarm Button

The Silent Alarm button is located beside the driver's seat and aft of the side console. Pushing the button prompts the destination signs to display a distress message.



 **NOTE:**

*Disengaging the silent alarm requires stopping the vehicle and cycling the Master Run switch from a run position to STOP-ENGINE and back. The engine will require a restart.*

## Emergency Brake Release Control Valve

This valve supplies the air pressure to release the rear brakes if the air system pressure drops below 40 psi (276 kPa) and the rear brakes apply automatically. Pushing down and holding the valve allows the air pressure to release the rear brakes. Releasing the valve knob shuts off the air pressure supply, allowing the rear brakes to re-engage.

 **NOTE:**

*The emergency brake release is for emergency use only. It allows the operator to move the vehicle away from a potentially dangerous location when the air system has failed. The rear brakes remain released as long as the valve is pressed. The brakes will drag at about 65 psi (448 kPa) even though the parking brake is in the released position.*

## Parking Brake Control Valve



**WARNING:**



**If the air pressure is below 40 psi (276 kPa), the parking brake valve will return to the applied position.**

The parking brake control valve controls the application or the release of the parking brake. Pulling up on the control knob applies the parking brake. Pushing down on the knob releases the parking brake.



## **Foot Operated Controls**

### **Brake Treadle**

The brake treadle, located to the left of the accelerator treadle, controls the application and release of the service brakes. The brake treadle also controls the retarder function. Refer to the Vehicle Operation Section of this manual for specific operating procedures on the retarder.

Brake application is proportional to the amount of treadle movement applied. Pressing the brake treadle illuminates the stop lights and the stop lights indicator.

### **Accelerator Treadle**

The accelerator treadle, located to the right of the brake treadle, controls the engine throttle. Acceleration of the engine is proportional to the amount of treadle movement applied.

### **Headlight Dimmer Switch**

The Headlight Dimmer switch is a heel-activated click-in switch located adjacent to the side console. Pressing the switch changes the headlight operating mode between either high beam or low beam. The blue high beam indicator on the instrument panel indicates the high beam mode.

### **Turn Signal Switches**

Two bracket-mounted, momentary-on switches control the right and left turn signal lights when held depressed. Left or right turn signal indicators on the instrument panel illuminate when respective floor switch is activated.

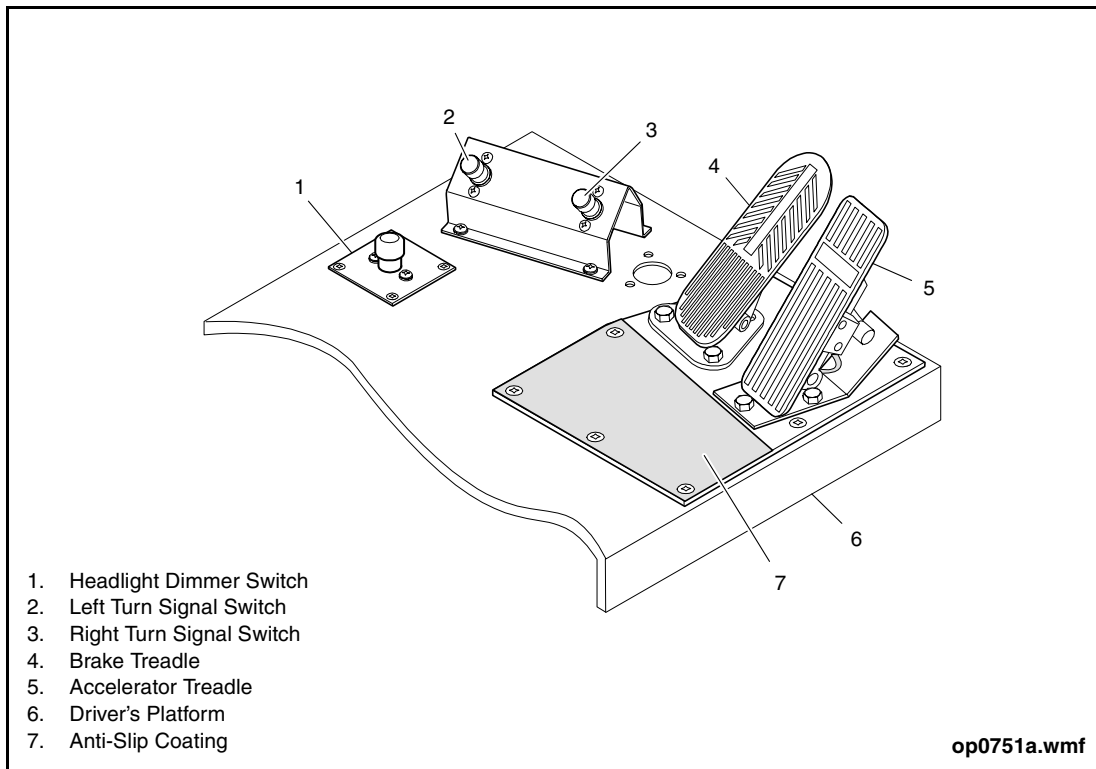

**Figure 18: Driver's Foot Controls**

## Miscellaneous Controls

### ABS Switch

The ABS switch, located in the destination sign compartment, is used by service personnel to troubleshoot the ABS System. Pulling the switch to BLINK CODE and releasing activates the blink code diagnostic capabilities. The blink code sequence displays on the instrument panel ABS Fail indicator.

### Service Light Switch

The Service Light switch is located behind the destination sign access door and controls the service lamp in the destination sign compartment.





## Door Master Switch

**WARNING:**

**Greater attention to passenger safety must be given whenever operating the vehicle with the Door Master switch in the OFF position, as this position disables several safety features and will allow the following conditions to occur:**

- **Vehicle can be moved with entrance and/or exit door open (brake interlocks disabled).**
- **Transmission can be shifted without foot on brake treadle.**
- **Transmission can be shifted and vehicle moved with wheelchair ramp deployed.**
- **Exit doors can be opened at any speed by using the emergency release control valve.**

The Door Master toggle switch, located in the destination sign compartment, controls power to the brake interlocks and exit door. When the switch is in the ON position, the entrance and exit doors are fully functional. In this mode, opening the exit door, kneeling the vehicle or operating the wheelchair ramp engages the interlocks. Engaging the interlocks applies the rear brakes and deactivates the accelerator.

In the OFF position, the brake interlocks are released (interlocks will not engage). The entrance door remains fully functional and the exit door does not function. A warning buzzer sounds and the Rear Door Open indicator illuminates on the instrument panel. In this mode, the exit door only opens if the emergency release control valve is activated. The control valve is located behind the breakable window to the left of the exit door.



## **Exhaust Filter Switch**

The Exhaust Filter switch, located in the front destination sign compartment, is a 3-way toggle switch with NORMAL, INHIBIT and REGEN positions. This switch is used by service personnel as required to regenerate or burn soot off of the muffler filter. This switch should be set to the NORMAL position for everyday vehicle operation and to the INHIBIT position when the vehicle is parked inside for servicing. When the switch is set to the REGEN position by service personnel, the engine speed and exhaust temperature will increase as the muffler filter regenerates. The High Exhaust Temp indicator on the instrument panel will also flash. When the switch is set to the NORMAL position, the muffler filter will automatically regenerate during regular vehicle operation. Engine exhaust temperatures will increase and the High Exhaust Temp indicator on the instrument panel will flash during this normal process. When the switch is set to the INHIBIT position the regeneration process is disabled. Refer to "High Exhaust Temp Indicator" in this manual for warnings applicable to the regeneration process.

## **Door Manual Control Valve**

This air control valve is located above the foot operated controls and on the side of the side console panel. Turning it to the OFF position releases the air controlling the entrance door. This allows manual operation of the door for initial vehicle entry. For normal entrance door operation, position the door manual control valve to ON.



## 7. VEHICLE OPERATION

### Pre-Start Checks & Adjustments

A daily routine inspection of the vehicle should reveal any required repairs or adjustments. These need to be reported to service personnel to maintain the best operating condition of the vehicle. When it is ready for service perform the following steps upon entry.

- Activate the Multiplexing System by turning the Master Run switch to the DAY-RUN or NIGHT-RUN position.
- Adjust the driver's seat for individual comfort.
- Adjust the tilt/telescopic steering column to suit.
- Adjust all mirrors for unobstructed views.
- Check that the Door Master switch is in the ON position.
- Check horn operation.

### Transmission Operation

**CAUTION:**

In temperatures below  $-20^{\circ}\text{F}$  ( $-29^{\circ}\text{C}$ ), set the Idle Speed switch on the side console to **FAST** to warm the transmission. Reset the switch to **NORMAL** before shifting from neutral [N], to reverse [R] or drive [D].

**CAUTION:**

Be sure to bring the vehicle to a full stop before shifting from drive [D] to reverse [R] or vice versa.

**WARNING:**

**NEVER** leave the driver's seat while the transmission is in gear.



The push button shift selector is used to select the transmission operating ranges, display transmission oil level, and display diagnostic codes. The LED display panel uses two green alpha-numeric characters to display these functions. The operating range buttons include:

- [R] Reverse - press this button to select reverse. The LED display panel will show [RR].
- [N] Neutral - press this button to select neutral. The LED display panel will show [NN].
- [D] Drive - press this button to select drive. The LED display panel will show [DD].

 **NOTE:**

*When the vehicle is operating in drive, the display panel will indicate the highest available range and the current operating range. Example: "52" would indicate 5 available forward speeds and operation is currently in the 2nd range.*

- (Up) Arrow - press this button when in drive [D] to request the next higher range. Continuously pressing the button will select the highest range available.
- (Down) Arrow - press this button when in drive [D] to request the next lower range. Continuously pressing the button will select the lowest range available.
- Mode - the mode button is used to view and toggle through diagnostic code information when the Diagnostic Code Display mode has been entered. The performance or economy mode feature is not available on this unit.

Operate the transmission using the following procedure:

1. Before starting the engine
  - a. Check that the transmission is in neutral [N].
  - b. Check that the parking brake is on.
  - c. Apply the brake treadle.
2. With the engine running and idling at normal speed, apply firm pressure on the brake treadle and make the desired range selection.
3. Release parking brake and the brake treadle to proceed.
4. To change direction, bring the vehicle to a full stop, apply firm pressure on the brake treadle and make the desired range selection.

 **NOTE:**

*A back-up alarm activates when selecting reverse [R].*



5. When parking or shutting down the vehicle come to a full stop, apply the parking brake, select neutral [N] and release the brake treadle.
6. To upshift or downshift the transmission, use the up or down arrow buttons respectively while in drive [D]. Pressing a button once changes the range by one. The second numeric character on the LED display will show the current operating range.

## Retarder Operation

The retarder is used to slow the vehicle and works in conjunction with the service (air) brakes. The retarder, located inside the transmission, is a fluid brake that creates drive-line deceleration. When activated, its housing fills with transmission fluid which impedes rotor and output shaft rotation slowing the vehicle. Retarders improve vehicle economy by extending the service life of the brake linings.

The retarder is supplemental to the operation of the service brakes. Overall braking efficiency (service brakes plus retarder) is affected by vehicle speed, road conditions and condition of the vehicle brakes, tires and mechanical systems. Retarder operation decreases in effectiveness as the vehicle slows down. It is the responsibility of the driver to drive the vehicle in a safe and controlled manner at all times.

The retarder operates in three stages and is only effective at speeds above 5 mph. Releasing the accelerator treadle engages the first stage of retarder operation. Lightly pressing on the brake treadle (the first 5° to 10° of movement) engages the second stage of retarder operation. Further brake application engages the third stage leading to full retarder operation. Releasing the brake treadle will disengage second and third stages. The retarder can be disabled using the Retarder switch on the side console panel.

Hitting a bump or pothole may activate the ABS system. The retarder will automatically be turned off if the ABS system is in active operation (ABS event) or if the accelerator is not fully released. When the ABS event deactivates, retarder operation will resume in approximately 6 seconds.

Retarder operation is attenuated and high gear is locked out if the transmission fluid becomes overheated. The retarder function is fully restored once the transmission fluid has cooled sufficiently or if the output shaft speed sensor detects a substantial increase in speed with the accelerator fully released (runaway vehicle).

 **NOTE:**

*Always be prepared to use the service brakes to stop the vehicle.*



## Anti-Lock Braking System

The Anti-Lock Braking System (ABS) functions to bring the vehicle to a safe, controlled stop during emergency braking situations. Through computer monitoring of wheel speeds the system controls brake pressure to prevent wheel lock-up. If during brake application the ABS system senses imminent wheel lock-up it engages automatically thus increasing vehicle stability and control. The ABS is inactive (no ABS event) whenever wheel deceleration difference remains within programmed limits.

An ABS Indicator on the instrument panel indicates any active faults and is also used by service personnel to retrieve codes.



**WARNING:**



**Keep stopping distances the same as those for similar non-ABS equipped vehicles.**

To operate under normal conditions use the standard braking technique. For emergency braking apply firm and constant pressure to the brake treadle. If required the ABS system will activate automatically producing a pulsing sensation to the brake treadle and a hissing sound. These are normal indications of ABS system operation. During emergency braking avoid “pumping” the brakes as this defeats the pulsing action of the ABS system and will increase your stopping distance.

 **NOTE:**

*Under certain operating conditions, the ABS system will override the transmission retarder. Refer to “Retarder Operation” in this manual for specific operating conditions which apply.*

If the ABS on one wheel malfunctions the system will retain normal braking on that wheel. Should the entire ABS System malfunction the system will also retain normal braking. The ABS Fail indicator on the instrument panel will illuminate if a malfunction occurs.

 **NOTE:**

*After ABS System service the ABS Fail indicator will remain illuminated at engine start-up. Driving the vehicle above 4 mph should extinguish the indicator. If the indicator remains illuminated, active faults are still present; contact service personnel.*



## Starting the Engine



**WARNING:**



**Put the shift selector in neutral [N] and apply the parking brake before starting the engine. If the parking brake indicator does not illuminate, DO NOT OPERATE THE VEHICLE.**

To operate the vehicle the Battery Disconnect switches must be in the ON position. Check the switches by opening the battery disconnect access door at the rear of the vehicle. These connect the engine starter and vehicle electrical circuits to the battery power.



**NOTE:**

*Refer to the Driver's Check List Section of this manual before operating the vehicle.*

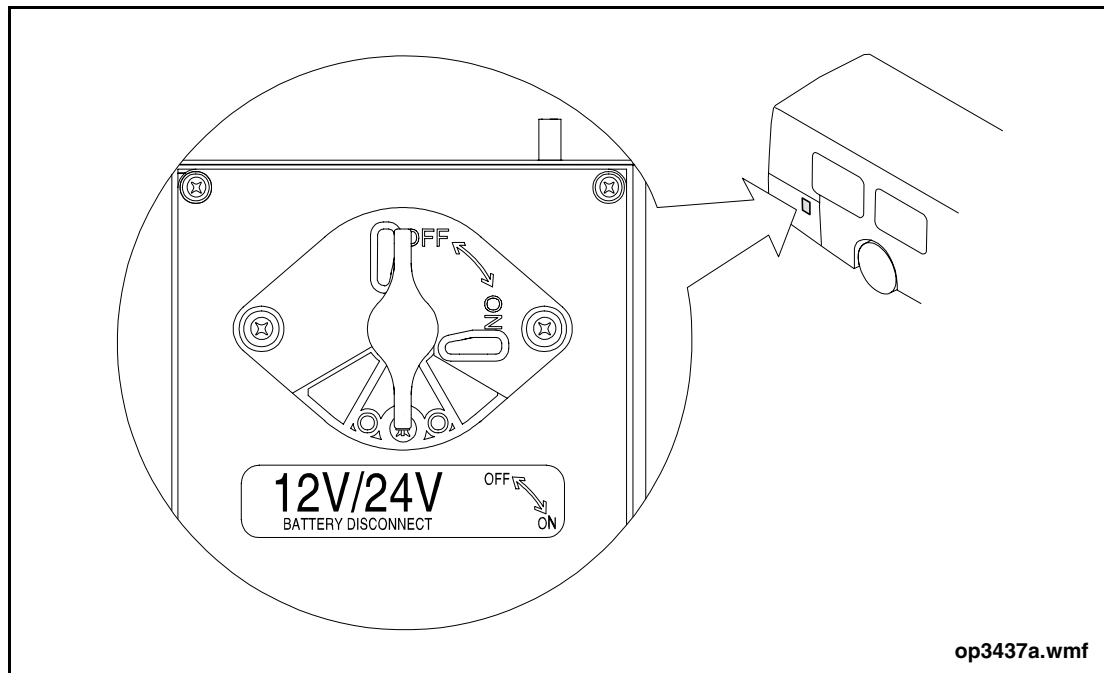

**Figure 19: Battery Disconnect Switch**

## Master Run Switch

Turn the Master Run switch (on side console) to DAY-RUN or NIGHT-RUN position. This activates the vehicle's Multiplexing System. Illuminated indicator lights and sounding alarms signify an active Multiplexing System.



### NOTE:

*When restarting less than 30 minutes after engine shut down, the Multiplexing System responds instantly.*

## Start Push Button



### WARNING:



**Put the shift selector in neutral [N] and apply the parking brake before starting the engine. If the parking brake indicator does not illuminate, DO NOT OPERATE THE VEHICLE.**

With the vehicle's Multiplexing System active, push the Start push button until the engine starter engages and starts the engine.

When the engine starts, release the push button.

If the starter fails to operate, check the following:

- The Master Run switch is in the DAY-RUN or NIGHT-RUN position.
- The Transmission Selector indicator shows neutral [N].
- The engine compartment Engine Run switch is in the FRONT position.
- The parking brake is applied.



### NOTE:

*The Multiplexing System limits continuous starter operation to 14 seconds; the starter circuit is then disconnected for 60 seconds to allow the starter to cool down.*





## Operational Checks

Once the engine is operating the operator should observe the following:

- The air system pressure is between 105 and 125 psi (724 and 862 kPa) and the suspension is at full height. The Air System requires a working pressure of 105 to 120 psi (724 to 827 kPa).
- The No Gen indicator is off when the engine is operating.
- Transmission Selector neutral [N] indicator remains illuminated.
- Parking brake and stop light indicator remain illuminated as long as the parking brake is applied.
- Door controller is operational.
- Position the Door Master switch to the OFF position and attempt to open the exit door by using the side console door controller. The exit door should not be operational; the entrance door should remain operational.
- Return the Door Master switch to the ON position.
- Wiper and washer controls are operational.
- Defroster/heater controls (on dash) are operational.
- Exterior lights operate during exterior light test. To conduct test, ensure engine is running and parking brake is applied, then press both turn switches simultaneously. All exterior lights will illuminate for two minutes.
- The destination sign controller is active.

## Parking Brake

The parking brake indicator illuminates when the parking brake is applied. If the parking brake indicator is not illuminated, apply the parking brake by pulling up on the parking brake control valve knob. If the parking brake indicator does not illuminate, **DO NOT OPERATE THE VEHICLE.**

Press the brake treadle before releasing the parking brake. Release the parking brake by pushing down on the control knob. The parking brake indicator extinguishes.

 **NOTE:**  
*Reapply parking brake.*



### **Stop Lights**

The stop lights indicator illuminates when the rear stop lights are on. If the indicator is not illuminated, check for rear stop light failure.

### **Low Air**

The Low Air indicator illuminates to warn of an unsafe air system pressure level. A warning buzzer sounds when the Low Air indicator is activated. **DO NOT OPERATE THE VEHICLE** until the alarm system is canceled.

The air pressure gauge indicates the air system pressure levels of the air brake system. The air system will maintain pressure levels above the low operating limit of 105 psi (724 kPa) during normal vehicle operation.

### **Check Engine**

The Check Engine indicator on the instrument panel illuminates momentarily before starting. The Check Engine indicator extinguishes before the engine starts. If the Check Engine indicator remains illuminated, **DO NOT OPERATE THE VEHICLE**.

### **Shift Selector Display**

At engine start-up the shift selector's red display shows [N] to indicate that the transmission is in neutral. This should occur automatically at each engine start-up.

### **No Gen**

When illuminated, the No Gen indicator signals that the alternator is **NOT** charging. The indicator remains illuminated until the engine starts. If the indicator fails to remain illuminated until the engine starts, **DO NOT OPERATE THE VEHICLE**.

### **Operator Display Keyboard (ODK) Messages**

Check that the destination sign control unit correctly programs electronic destination sign messages.



## Rear Door Open Indicator

Move the door controller to position #3, #4 or #5 to check that the Rear Door Open indicator illuminates when the doors open.

**NOTE:**

*Exit doors will open and the interlocks will be engaged.*

Turning the door controller handle to position #1 closes the entrance and exit doors and extinguishes the Rear Door Open indicator. Check that the exit doors are closed. If the exit doors are not closed and the Rear Door Open indicator is still illuminated, **DO NOT OPERATE THE VEHICLE.**

## Day-Time Operation

When the engine is operating, check the following:

- The air system pressure is between 105 and 125 psi (724 and 862 kPa) and the suspension is at full height. The air system requires a working pressure of 105 to 120 psi (724 to 827 kPa).
- The No Gen indicator is off when the engine is operating.
- Transmission Shift Selector neutral [N] indicator remains illuminated.
- Parking brake and stop light indicator remain illuminated as long as the parking brake is applied.
- Daytime running lights operation.
- Front, side and rear destination/route sign lights.
- Door controller operation.
- The Door Master switch, when placed in the OFF position, disables the exit door and inhibits the brake interlocks.
- Aisle lights operation.
- Return the Door Master switch to the ON position.
- Wiper and washer controls operation.
- Defroster/heater control (on dash) operation.

## Night-Time Operation

For night-time operations, ensure the Master Run switch is placed in the NIGHT-RUN position. Check the following in addition to the day-time checks:

- Instrument panel illumination lights.
- Headlight operation (high and low beam).
- Front and rear identification and marker lights.
- Tail lights.
- License plate light.
- Panel lights dimmer changes the brightness of instrumentation backlights and panel text.
- Interior fluorescent lights can be turned on using the Aisle Lights switch.

## Pre-Trip Brake Test



**WARNING:**



**Before driving the vehicle conduct the following test sequence. If the test reveals a fault, advise service personnel and DO NOT OPERATE THE VEHICLE.**

Conduct the following test sequence to ensure that the air brake system is functioning properly.

1. Apply the parking brake.
2. Start the engine, set the Idle Speed switch to FAST and check the following:
  - a. The low pressure warning devices switch off as the air pressure builds.
  - b. If the air pressure gauge reading was below 90 psi (620 kPa), the reading increases back to 90 psi (620 kPa) in less than three minutes.
  - c. The air pressure gauge reading levels off at 120 to 125 psi (827 to 862 kPa).
3. Release the parking brake.
  - a. Make multiple light brake treadle applications and check the following:
    - i. The air pressure gauge reading stabilizes at 105 psi (724 kPa) as the air compressor begins its pumping cycle.



- ii. After continued multiple light brake treadle applications the low pressure warning devices activate as the air pressure gauge reading falls to 75 psi (517 kPa).
  - b. Release the brake treadle and reapply the parking brake.
4. Allow the air system to fully recharge.
5. Stop the engine and proceed as follows.
- a. Release the parking brake.
  - b. Apply the brake treadle fully, hold and check the following:
    - i. Upon treadle application the air pressure gauge reading does not drop more than 18 psi (124 kPa).

 **NOTE:**

*Tap the gauge to be sure the needle is not stuck.*

- ii. The air pressure does not drop more than 3 psi (20 kPa) per minute.
    - iii. There are no audible air leaks.
  - c. Release the brake treadle and apply the parking brake.
6. Restart the engine.
- a. Set the Fast Idle switch to FAST to recharge the air system.
  - b. When the reading levels off at 120 to 125 psi (827 to 862 kPa), switch off the fast idle.
  - c. Release the parking brake.
7. Move the vehicle slowly and test brake response.



## Moving the Vehicle

1. Fasten driver's seat-belt (as required by law).
2. Close the doors by turning the door controller handle to position #1. The Rear Door Open indicator should be off.
3. Apply the brake treadle and release the parking brake. The parking brake indicator extinguishes.
4. Shift the Transmission Selector into the desired gear.

 **NOTE:**

*The neutral [N] indicator extinguishes and the appropriate range letter appears in the display.*

5. Release the brake treadle and lightly apply the accelerator treadle to slowly move vehicle from the parking area. The stop lights indicator extinguishes.
6. Check the steering wheel for vibrations, looseness or binding while the vehicle is in motion. If any abnormalities are present, DO NOT OPERATE THE VEHICLE.



## Parking the Vehicle



**WARNING:**



**The parking brake must be applied when parking the vehicle. When parking downhill, be sure the front wheels are turned into the curb; when parking uphill, be sure the front wheels are turned away from the curb.**

1. Bring the vehicle to a complete stop using the brake treadle. The stop lights indicator illuminates. Shift the transmission selector into neutral [N].
2. Apply the parking brake and release the brake treadle. The parking brake indicator illuminates.
3. Open the entrance door by placing the controller in position #2.
4. Turn the Master Run switch to the STOP-ENGINE position.
5. Exit the vehicle.
6. Manually close the doors.

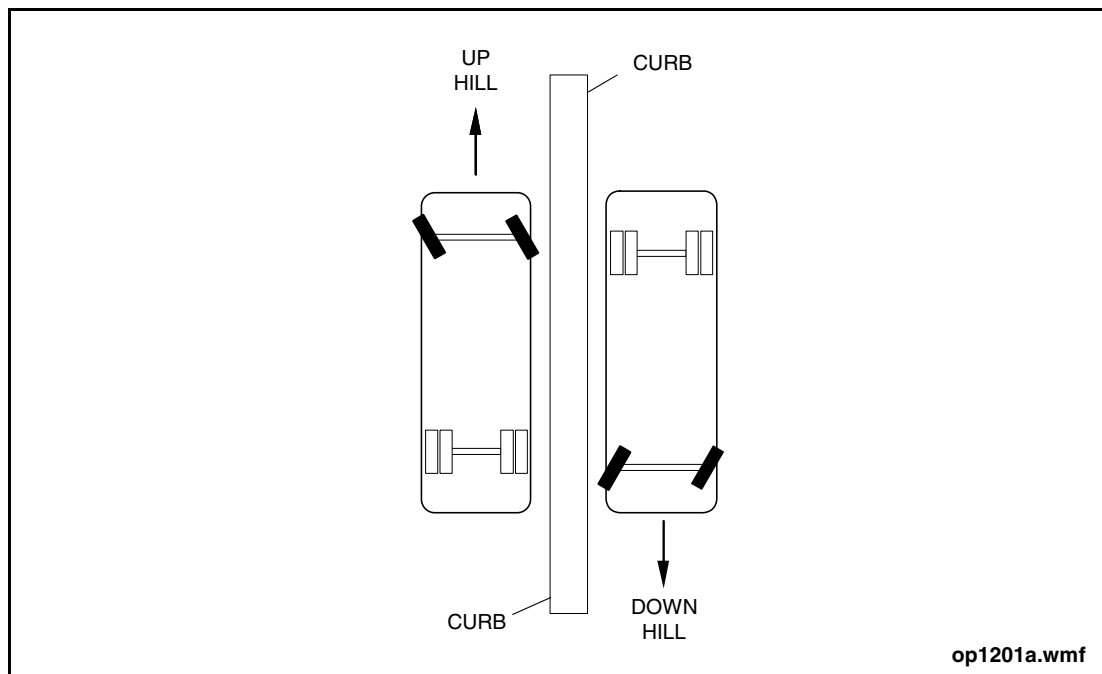

**Figure 20: Parking on an Incline**

## Jump Start Connection

Behind the battery access door is a jump start connector to supply power to the batteries when normal engine starting is not possible. It uses a quick connect assembly to ensure a safe and correct electrical connection to the battery poles.

 **NOTE:**

*Advise service personnel if starting difficulties occur.*

## Engine Protection System



**CAUTION:**



**If engine shutdown occurs, DO NOT attempt an engine restart unless absolutely necessary. Continuing engine operation without fault correction may result in engine damage.**

The New Flyer vehicle is equipped with an automatic shut down system to prevent engine damage. If the Stop Engine indicator illuminates, the Engine Protection System initiates a power reduction cycle that lasts 30 seconds. After that time the engine will shut down.

 **NOTE:**

*Use the 30 seconds to remove the vehicle from traffic. Contact service personnel for further instructions.*

## Kneeling

An amber lamp located beside the front entrance door indicates when the kneeling system is in operation. A warning beep also sounds.

### Kneeling Procedure

1. Bring the vehicle to a complete stop, put shift selector in neutral, apply the parking brake and set the door controller to Position #2 to open the entrance door. Kneeling will not be enabled if the door is closed.



**NOTE:**

*Brake and accelerator interlocks engage when the entrance door is open and kneeling is in process.*

**WARNING:**

**Prior to kneeling the vehicle, ensure that boarding passengers stand clear of the vehicle and no obstructions exist.**

2. Lift the switch guard and hold the Kneel switch in the LOWER position until the vehicle is completely kneeled. Boarding passengers must stand clear and wait until the vehicle has lowered, before entering the vehicle.
3. Set the Kneel switch to the RAISE position and close the switch guard once passengers have safely boarded. The vehicle will raise automatically to its full ride height.

### **Kneeling Exterior Signal**

An amber lamp located beside the entrance and exit doors indicates when the kneeling system is in operation. A warning beep also sounds.

## **Passenger Signal System**

This passenger signal system is activated by the following devices:

- Stop request cord
- Exit door stanchion push button
- Luggage rack and vertical stanchion push buttons
- Wheelchair area push button

Activating the signal system causes the following to occur:

- Stop request sign illuminates. The sign extinguishes when the system is reset.
- Stop Request indicator on instrument panel remains illuminated until the system is reset.
- A chime sounds once when the passenger signal system is activated. A different tone sounds if the wheelchair passenger signal system is activated.



The system is cancelled (reset) and the lights are extinguished by:

- Opening the entrance door with the door controller.
- Opening the exit door, once enabled with the door controller.

The stop request sign extinguishes when the entrance or exit doors are fully open.

### Stop Request Cord

Stop request cords are located on either side of the vehicle interior. Pulling a cord activates the system.

### Stop Request Buttons

Stop request buttons are located on the luggage rack stanchions, vertical stanchions and exit door stanchion. Pressing a button activates the system.

### Wheelchair Stop Request Push Buttons

Stop request push buttons are located under each longitudinal hinged seat in the wheelchair stations. Pushing a button activates the passenger signal system. A chime sounds a different tone to alert of a wheelchair passenger stop request.

### Entrance & Exit Door Lights

The entrance and exit doorways are lit by header lights (above the door) and exterior overhead lights. Moving the door controller to open a door activates these lights. The lights extinguish as the doors close.

 **NOTE:**

*The exit door curb lights extinguish after a five second delay.*



## 8. WHEELCHAIR SYSTEM

The wheelchair system consists of a wheelchair ramp and wheelchair restraint system.

### Wheelchair Ramp

The New Flyer vehicle is equipped with a wheelchair ramp system to assist passengers in boarding and exiting the vehicle.



**WARNING:**



**Ensure the following conditions are met prior to operating the wheelchair ramp:**

- **Ensure passenger safety during the wheelchair ramp operations. Monitor the passenger's position during the operation cycle.**
- **Loading or unloading the passengers must be performed in a flat, open area. DO NOT deploy the ramp where trees, telephone poles, fire hydrants, or similar obstacles may jeopardize passenger safety or damage the ramp.**
- **Be familiar with ramp functions and operation before operating the equipment.**
- **DO NOT conduct the "STOW" operation with a passenger on the lift.**
- **Passengers are to board the ramp only when it's at ground level, and the "DEPLOY" cycle is complete.**



**CAUTION:**



**Release the switch after the ramp has passed the 90° position. This prevents the oil and pump from overheating.**

The switch to control this feature is located on the instrument panel. The three positions of the switch enable the wheelchair ramp mechanism to perform the following operations:



**NOTE:**

*When the ramp is in STOW or DEPLOY, the brake interlocks are activated. The vehicle will not move until the ramp is fully stowed and the switch is in the FLOAT position.*

## DEPLOY

This position activates the ramp from the closed position to the open position.

## FLOAT

This position shuts off power to the pump, allowing the ramp to free-fall to either the open or the closed position. Upon cycle completion, this becomes an off position.

## STOW

This position is used to move the ramp from the open to the closed position.



**NOTE:**

*When the wheelchair ramp is in motion, an audible alarm sounds, and the exterior lift warning light illuminates and flashes.*

## Deploying the Ramp

1. Bring the vehicle to a complete stop in a flat, unobstructed area, one to three feet from the curb. Check for obstructions and be certain that there is adequate clearance to deploy the ramp.
2. Apply the parking brake.
3. Place the transmission shift selector in neutral [N].
4. Kneel vehicle if required.



**NOTE:**  
*Parking brake and stop light indicators on the instrument panel will illuminate.*

5. Move the door controller to the door open position.



**CAUTION:**

**Make sure the area in which the ramp will DEPLOY is clear of people and any obstructions.**

6. Move the Ramp toggle switch to DEPLOY.

7. After the ramp has passed the vertical 90° position, release the switch. The ramp continues to lower until it reaches the ground.

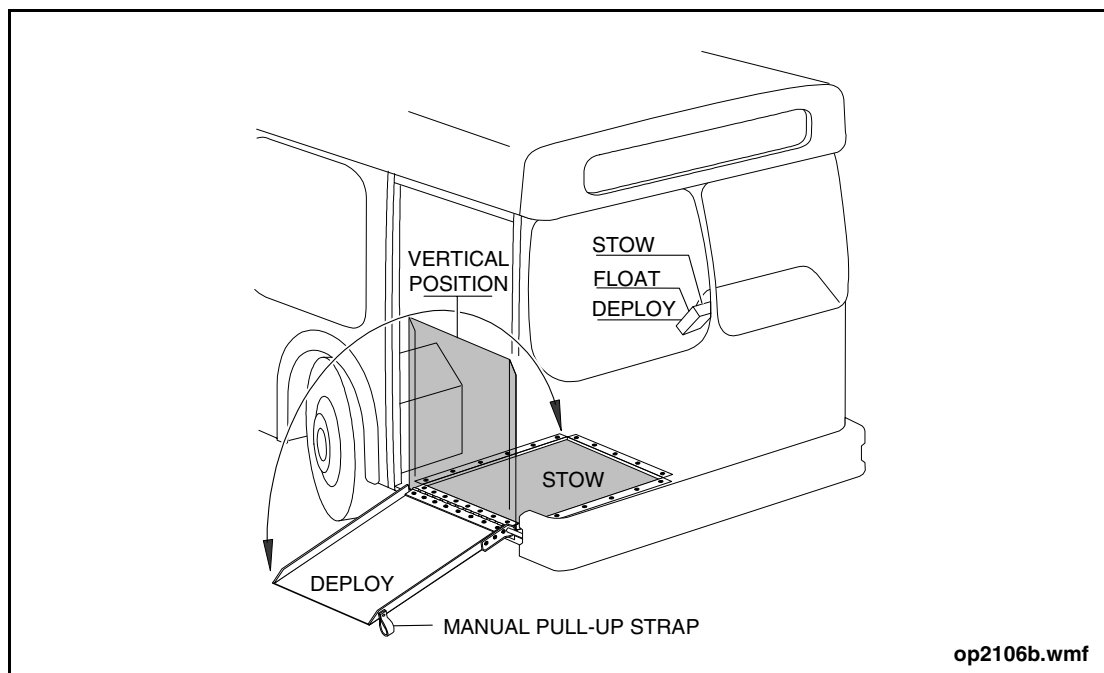

**Figure 21: Wheelchair Ramp Operation**

## Raising the Ramp



**WARNING:**



**Check for obstructions and be sure that all passengers are at a safe distance. Keep objects and passengers off the lift platform during the STOW operation.**

1. Once the passenger has boarded the vehicle safely and is clear of the ramp, move the toggle switch to the STOW position.



**NOTE:**

*An audible alarm sounds when the ramp is moving.*

2. Raise the vehicle from the kneeling position.
3. Close the entrance door.
4. Disengage the parking brake and proceed to the next stop.

## Ramp Emergency Procedures

In case the wheelchair ramp power unit fails, the unit may be hand-operated by using a pull-up strap located on the ramp's corner.



## Wheelchair Restraint System

The forward seat positions are equipped with a Wheelchair Restraint System for security of handicapped passengers. For optimum passenger safety be sure to follow the operating procedures to complete all the necessary restraint system connections.



**CAUTION:**



**The wheelchair wheel-lock is for use on large diameter steel wheels only. Use both rear red belts if not using the wheel-lock.**

### Operating Procedures

1. Move the flip-up seat cushion up to the lock position.
2. Pull the lock release lever to open the wheel lock.
3. Back the wheelchair's rear wheel into the wheel-lock until it engages and set the wheelchair brake.
4. Locate the two tie-down belts under the double flip-up seat and attach each belt to solid rear frame members of the wheelchair as follows:
  - a. Operate tie-down belt release handle on underside of the double flip-up seat.
  - b. Pull the belt release handle to release each tie-down belt.
  - c. Attach extended end of each tie-down belt to a solid rear frame member of the wheelchair.
  - d. Move the release handle back into position to take up the belt slack.
  - e. Check belts to ensure they are secure.
5. Secure the passenger by extending the window side lap belt across to the aisle side clip and fasten. The aisle side clip is attached to the seat frame of the flip-up seat.
6. Check the belt locks by pulling on each end to ensure they are engaged.

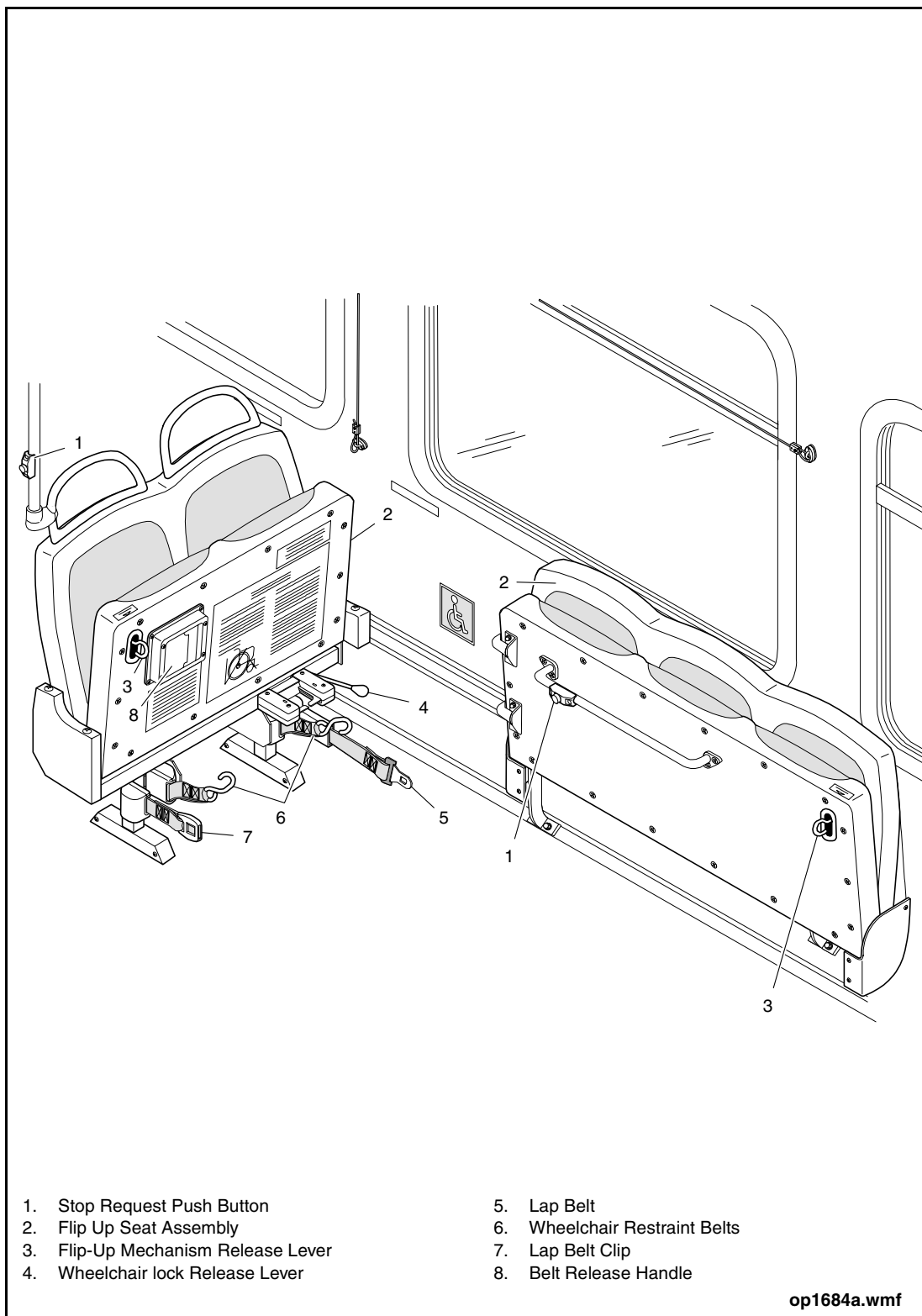

**Figure 22: Wheelchair Restraint System**





## 9. BIKE RACK SYSTEM

**WARNING:**

**Loading or unloading bike from the streetside endangers the passenger. LOAD OR UNLOAD THE BIKE FROM THE CURB-SIDE ONLY.**

The bike rack system allows the passenger to load and unload a bike without driver assistance. In the case of children under ten, however, have an adult assist in loading and unloading the bike.

Be sure to load and unload the bike from either the front of the rack or from the curbside.

### Loading Operation

**CAUTION:**

**To ensure safe vehicle operation, NEVER load a bike onto the bike rack which will in any way obstruct the headlamps. ALWAYS verify that the headlamps are unobstructed whenever a bike has been loaded onto the bike rack.**

1. Remove water bottles, pumps or other loose items from bike prior to loading.
2. Squeeze bike rack handle UP to release latch.
3. Fold down bike rack.
4. Lift bike onto rack, fitting wheels into proper wheel slots.
5. Raise the support arm over the front tire so that the hook rests at the highest point on the front wheel. Bike is now held firmly in place.

### Unloading Operation

1. Unload from curb or from in front of vehicle.
2. Raise support arm off the tire.
3. Lift bike out of wheel slots and set down.
4. If there are no other bikes on the rack, lift it until the rack swings into the lock position against the vehicle.



## **10.NOTES**





**NEW FLYER**

**PUBLICATIONS**

25 DeBaets Street  
Winnipeg, Manitoba  
R2J 4G5

Tel. (204) 982-8431  
Fax (204) 667-5769  
<http://www.newflyer.com>

Printed in Canada